

Accessibility Requirements under State and Federal Law



Vickie Simpson, Policy Advisor
Disability Rights Bureau
Illinois Attorney General Lisa Madigan

Disability Rights Bureau Overview

- Charged with enforcement of the Environmental Barriers Act and Illinois Accessibility Code
- Help to protect the rights of people with disabilities
- Only Disability Rights Bureau in an AG's office
- Offices in Springfield and Chicago
- Staff includes Disability Specialists, Paralegal, Policy Advisor, Administrative Assistant and Attorneys

What we do

- Architectural accessibility investigations
- Technical assistance
- Trainings, presentations and public awareness
- Committees
- Legislation
- Litigation

Illinois Environmental Barriers Act

- Governs physical access for people with disabilities.
- For facilities built or altered after 1985, the EBA requires that new or altered elements be accessible.
- Applies to new construction, additions and alterations.
- Section 25/5(e) – Government lease, rent or use section.

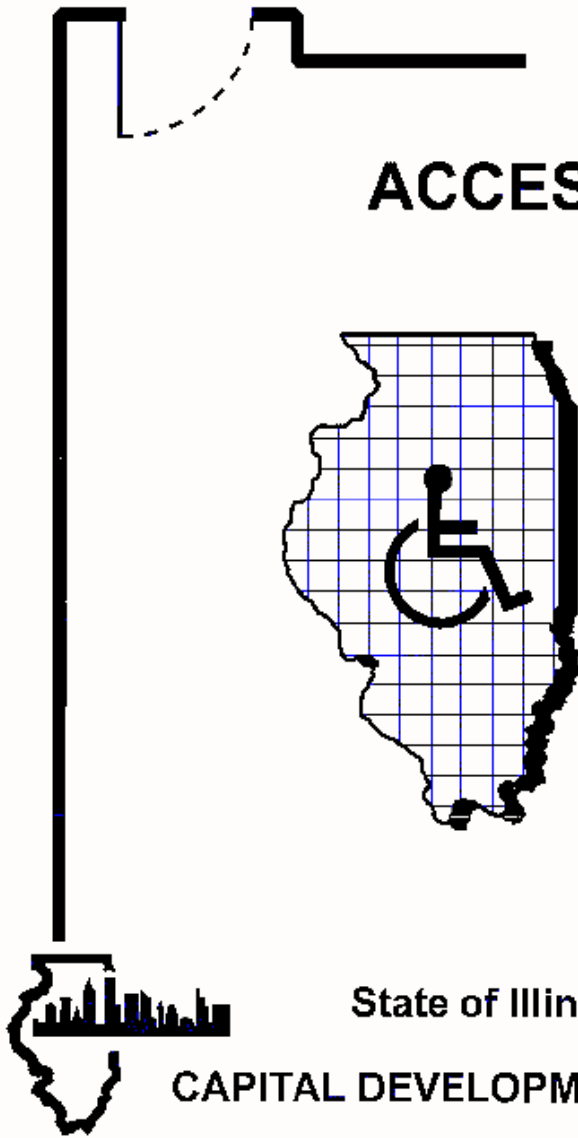

ILLINOIS

ACCESSIBILITY

CODE

EFFECTIVE

APRIL 24, 1997

State of Illinois

CAPITAL DEVELOPMENT BOARD

Environmental Barriers Act and the Illinois Accessibility Code covers:

- Public Facilities – newly constructed or altered
 - Government buildings
 - Restaurants
 - Grocery Stores
 - Gas Stations
 - Courthouses
 - Theaters
 - Hotels
 - Sports Facilities
 - Religious Entities
 - Newly Constructed Multi-story Housing
- Public is defined by the IAC as “any group of people who are users of the building and employees of the building”

Specific Facility Types

IAC §400.320

- Auditorium and Assembly Areas
- Automated Teller Machines
- Dressing and Fitting Rooms
- Medical Care Facilities
- Housing Owned or Financed by a Governmental Unit
- Libraries
- Accessible Transient Lodging
- Business and Mercantile
- Museums and Exhibition Areas
- Public Facilities which Primarily Serve Children
- Recreational Facilities
- Restaurants and Cafeterias
- Temporary Buildings and Facilities
- Tenant Work
- Transportation Terminals/Stations and Shopping Malls
- Detention and Correctional Facilities

Who's who with regard to the EBA/IAC

- **Private sector**

- Architects
- Engineers
- Building owners/tenants

- **Local Level**

- Building code officials review plans prior to issuing building permits.

- **State Level**

- Capital Development Board charged with issuing interpretations.
- Attorney General's Office charged with investigation of complaints and legal enforcement.

Our Complaint Process

Complaints can be sent by mail, email, fax, received over the phone, or through the OAG website.

We review all complaints that we receive as a team. We determine whether the AG has jurisdiction to open an investigation in response to each complaint.



LISA MADIGAN

Illinois Attorney General
Disability Rights Bureau
100 West Randolph, 11th Floor
Chicago, IL 60601
312-814-5684
1-800-964-3013

Email: disabilityrights@atg.state.il.us
www.illinoisattorneygeneral.gov

Fill out the form online and click submit at the end of the form to send by email or print and mail to the address above. Include copies (no originals please) of any supporting documents.

YOUR INFORMATION:	PERSON OR ENTITY YOU ARE COMPLAINING ABOUT:
Name: Mr. <input type="checkbox"/> Mrs. <input type="checkbox"/> Ms. <input type="checkbox"/> (check one)	Name: _____
Address: _____	Type of Facility (Examples include: restaurant, hotel, doctor's office): _____
City: _____ State: _____ Zip Code: _____ County: _____	Contact Person (Examples include: supervisor, manager): _____
Your Telephone Number:	Address: _____
Daytime: - - Ext: _____	City: _____ State: _____ Zip Code: _____ County: _____
Evening: - - Ext: _____	Telephone: - - Ext: _____
Cell: - - _____	Website: _____
Your e-mail address: _____	Are you currently employed by the entity you are complaining about? Yes <input type="checkbox"/> No <input type="checkbox"/>
Preferred phone number(s) for communications with our office regarding your complaint: <input type="checkbox"/> Daytime Phone <input type="checkbox"/> Evening Phone <input type="checkbox"/> Cell Phone	
YOUR COMPLAINT	DO NOT SEND ORIGINALS
Please describe, in as much detail as possible, the incident or condition that is the subject of this complaint. You may use additional sheets if necessary.	
_____ _____ _____ _____ _____ _____ _____ _____ _____ _____	
CONTINUE ON NEXT PAGE	

Our Complaint Process continued...

If there is NO Jurisdiction...

- If there is no evidence of a pattern or practice of discrimination, we will not open an investigation. Instead, we will give the complainant technical assistance and/or referrals.

If there is Jurisdiction...

- If there is reason to believe that there is a pattern or practice of discrimination or an architectural violation, we will open an investigation. Generally, we:
 - 1. Request information from the respondent and other relevant sources.
 - 2. Investigate, research, survey the premises, hold a meeting with the respondent, etc.
 - 3. Seek voluntary compliance/settlement: change policy, address all barriers OAG identified, train staff, etc.
 - 4. Consider litigation if necessary.

Other Illinois regulations

- Illinois Department of Transportation
 - Motor Fuel Sales Tax
 - State funded projects
 - Administration of federal highway funds
 - On-street accessible parking
 - Sidewalk width = 4'
- Illinois Department of Public Health
 - License plumbers and register plumbing contractors
 - Minimum fixture count
 - Food service and gas stations must provide public restrooms unless exempted.
 - Change of use
 - Swimming facilities
- Illinois Historic Preservation Agency
- Local codes/regs

Americans with Disabilities Act

- Title I – Employment
- Title II – State and local government
- Title III – Public accommodations and commercial facilities
- Title IV – Telecommunications
- Title V – Miscellaneous

Title II – ADA

Compliance dates

Appendix to § 35.151(c)

Compliance Date for New Construction or Alterations	Applicable Standards
Before September 15, 2010	1991 Standards or UFAS
On or after September 15, 2010, and before March 15, 2012	1991 Standards, UFAS, or 2010 Standards
On or after March 15, 2012	2010 Standards

Compliance Date for Title II

If the start date for construction is on or after March 15, 2012, all newly constructed or altered State and local government facilities must comply with the 2010 Standards. Before that date, the 1991 Standards (without the elevator exemption), the UFAS, or the 2010 Standards may be used for projects when the start of construction commences on or after September 15, 2010.

Safe Harbor – Existing Facilities

- Elements that comply with 1991 Standards do not need to be modified to meet the 2010 Standards unless those elements are altered on or after March 15, 2012.
- Safe Harbor does not apply to elements in existing facilities that were not subject to specific requirements in the 1991 Standards.

2010 ADA Standards

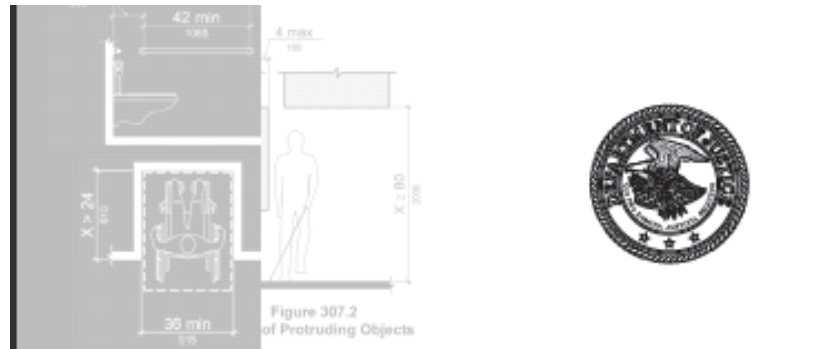

2010 ADA Standards for Accessible Design

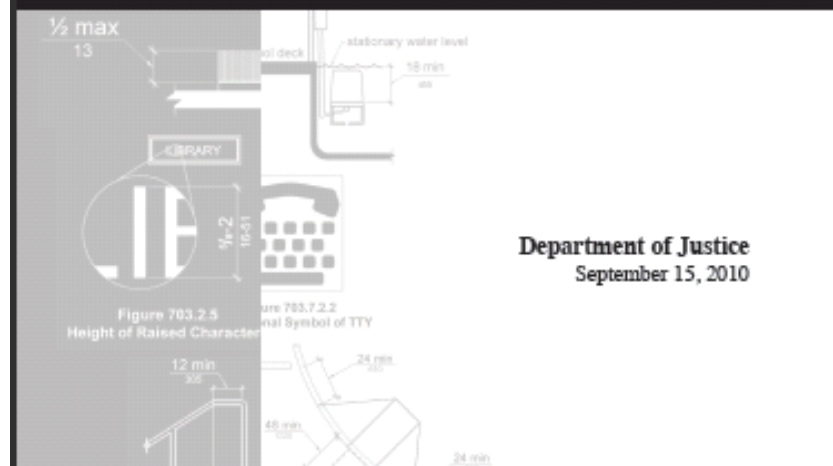

2010 ADA Standards

- Chapter 1: Application and Administration
- Chapter 2: Scoping Requirements
- Chapter 3: Building Blocks
- Chapter 4: Accessible Routes
- Chapter 5: General Site and Building Elements
- Chapter 6: Plumbing Elements and Facilities
- Chapter 7: Communication Elements
- Chapter 8: Special Rooms, Spaces and Elements
- Chapter 9: Built-in Elements
- Chapter 10: Recreational Facilities

Chapter 2 – Scoping Requirements

206.4 Entrances. *Entrances* shall be provided in accordance with 206.4. *Entrance* doors, doorways, and gates shall comply with 404 and shall be on an *accessible* route complying with 402.

EXCEPTIONS: 1. Where an *alteration* includes *alterations* to an *entrance*, and the *building* or *facility* has another *entrance* complying with 404 that is on an *accessible* route, the *altered entrance* shall not be required to comply with 206.4 unless required by 202.4.

2. Where exceptions for *alterations* to *qualified historic buildings* or *facilities* are permitted by 202.5, no more than one *public entrance* shall be required to comply with 206.4. Where no *public entrance* can comply with 206.4 under criteria established in 202.5 Exception, then either an unlocked *entrance* not used by the public shall comply with 206.4; or a locked *entrance* complying with 206.4 with a notification system or remote monitoring shall be provided.

206.4.1 Public Entrances. In addition to *entrances* required by 206.4.2 through 206.4.9, at least 60 percent of all *public entrances* shall comply with 404.

206.4.2 Parking Structure Entrances. Where direct access is provided for pedestrians from a parking structure to a *building* or *facility entrance*, each direct access to the *building* or *facility entrance* shall comply with 404.

404 Doors, Doorways, and Gates

404.1 General. Doors, doorways, and gates that are part of an *accessible* route shall comply with 404.

EXCEPTION: Doors, doorways, and gates designed to be operated only by security personnel shall not be required to comply with 404.2.7, 404.2.8, 404.2.9, 404.3.2 and 404.3.4 through 404.3.7.

Advisory 404.1 General Exception. Security personnel must have sole control of doors that are eligible for the Exception at 404.1. It would not be acceptable for security personnel to operate the doors for people with disabilities while allowing others to have independent access.

404.2 Manual Doors, Doorways, and Manual Gates. Manual doors and doorways and manual gates intended for user passage shall comply with 404.2.

404.2.1 Revolving Doors, Gates, and Turnstiles. Revolving doors, revolving gates, and turnstiles shall not be part of an *accessible* route.

404.2.2 Double-Leaf Doors and Gates. At least one of the active leaves of doorways with two leaves shall comply with 404.2.3 and 404.2.4.

404.2.3 Clear Width. Door openings shall provide a clear width of 32 inches (815 mm) minimum. Clear openings of doorways with swinging doors shall be measured between the face of the door and the stop, with the door open 90 degrees. Openings more than 24 inches (610 mm) deep shall provide a clear opening of 36 inches (915 mm) minimum. There shall be no projections into the required clear opening width lower than 34 inches (865 mm) above the finish floor or ground. Projections into the clear opening width between 34 inches (865 mm) and 80 inches (2030 mm)

General Exceptions/Exemptions

- IAC – Check relevant section and section 400.330
- Standards – Check Chapter 2 (Scoping) and any technical chapters to determine if an Exception or Exemption applies.

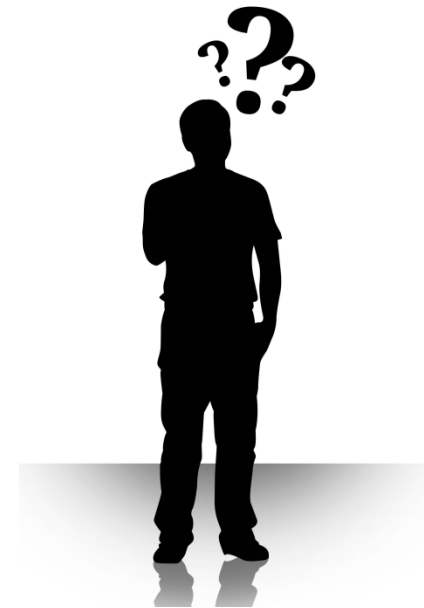

Building Access

- Includes what elements?
- Who is responsible for access?

Accessible Route

- At least one accessible route from:
 - Streets and sidewalks
 - Public transportation stops
 - Taxi stands
 - Accessible parking spaces
 - Passenger loading zones

...to an accessible building entrance.

- At least one accessible route shall connect accessible buildings, accessible facilities, accessible elements, and accessible spaces that are on the same site.

Accessible Route

- Exterior routes may include parking access aisles, curb ramps, ramps, sidewalks, etc.
- Interior routes may include floors, hallways, doors, elevators, etc.
- Accessible routes must be made of firm, stable and slip resistant materials.
- Minimum width = 36" (*see passing space)
- Protruding objects
- Cross (1:50) and running slope (1:20)
- Changes in level



APR 21 2005

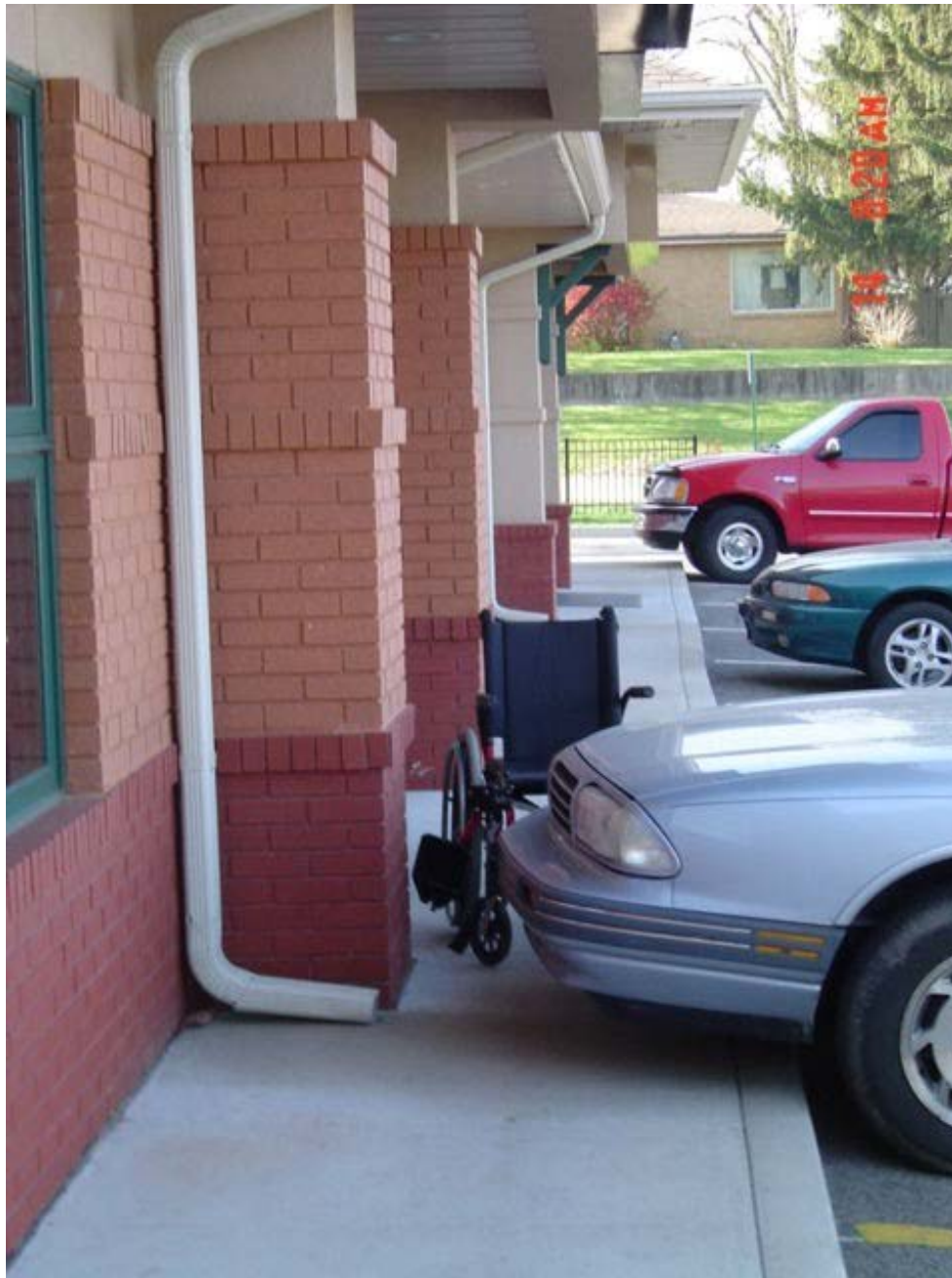



Floor & Ground Surfaces



Ground/Floor Surfaces



- Firm, stable and “slip resistant”

Carpet

- ½” maximum pile height (measured to the backing, cushion, or pad)
- Texture: level or textured loop, level cut pile, or level cut/uncut pile
- Firm backing, cushions, pads (or no cushions/pads for greater firmness)
- Firm securement, backing
- IAC 400.310(a)(11)

Carpet



- Securement/attachment to prevent rolling or buckling.

Changes in Level



- Apply to all level changes along accessible routes, including door thresholds.

Changes in Level

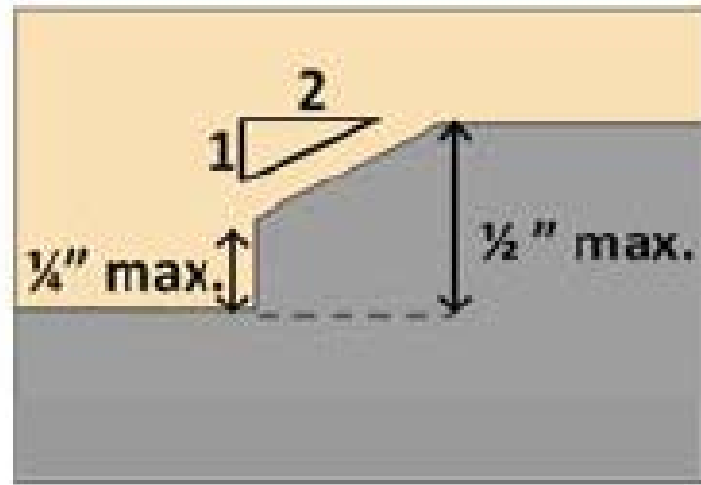
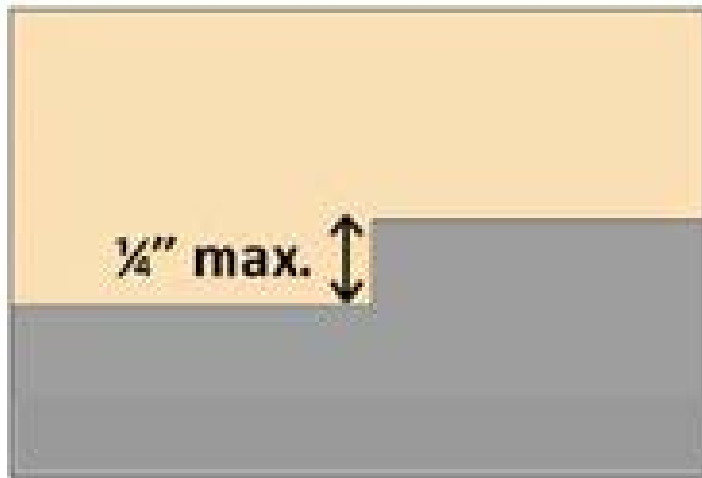

- 1/4" maximum – no treatment
- 1/2" maximum – but need to bevel at a max. of 1:2
- > 1/2" – treat as ramp/other means of vertical access





NOV 18 2008

Curb ramps

(Not located on a public right-of-way)

- Curb ramp - A short ramp cutting through a curb or built up to it.
 - Location of a curb ramp – shall be provided wherever an accessible route crosses a curb.
 - Slope – running = 1:12 (8.33%); cross = 1:50 (2%)
 - Width - 36" minimum
 - **Detectable warning – not required**
 - Obstructions – located or protected to prevent their obstruction by parked vehicles.

Curb Ramps

- Where a pedestrian walks across a curb ramp, or where it is not protected by handrails/guardrails it shall have flared sides.
 - Maximum slope of flared sides = 1:10
- Curb ramps may have returned curbs where pedestrians do not walk across the curb.

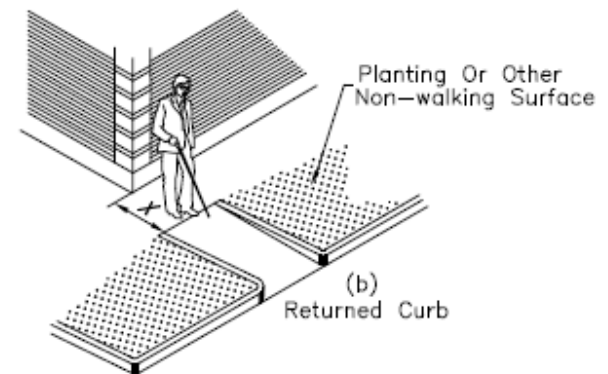
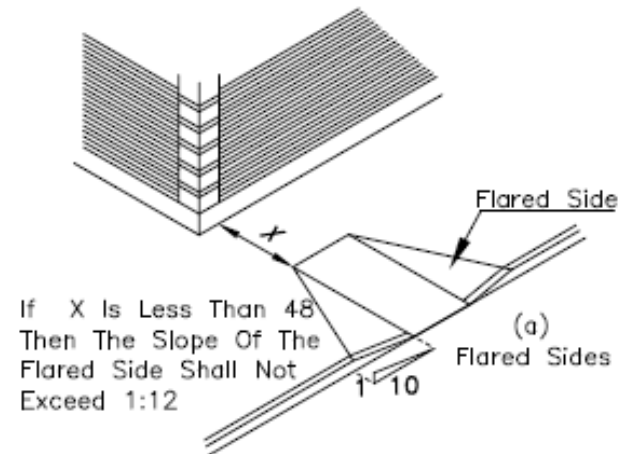

Curb Ramps

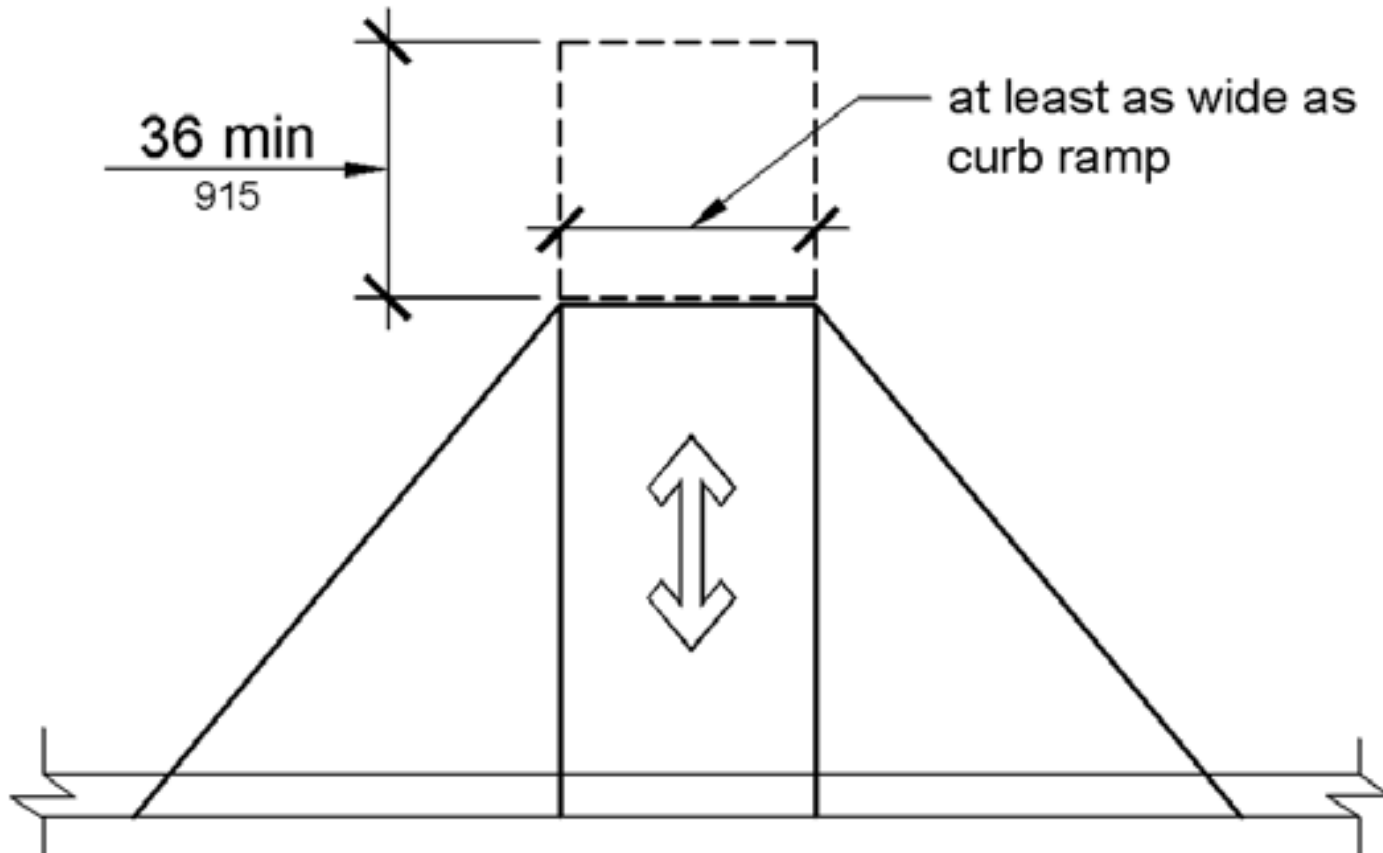

Landing 36" min. required at the top

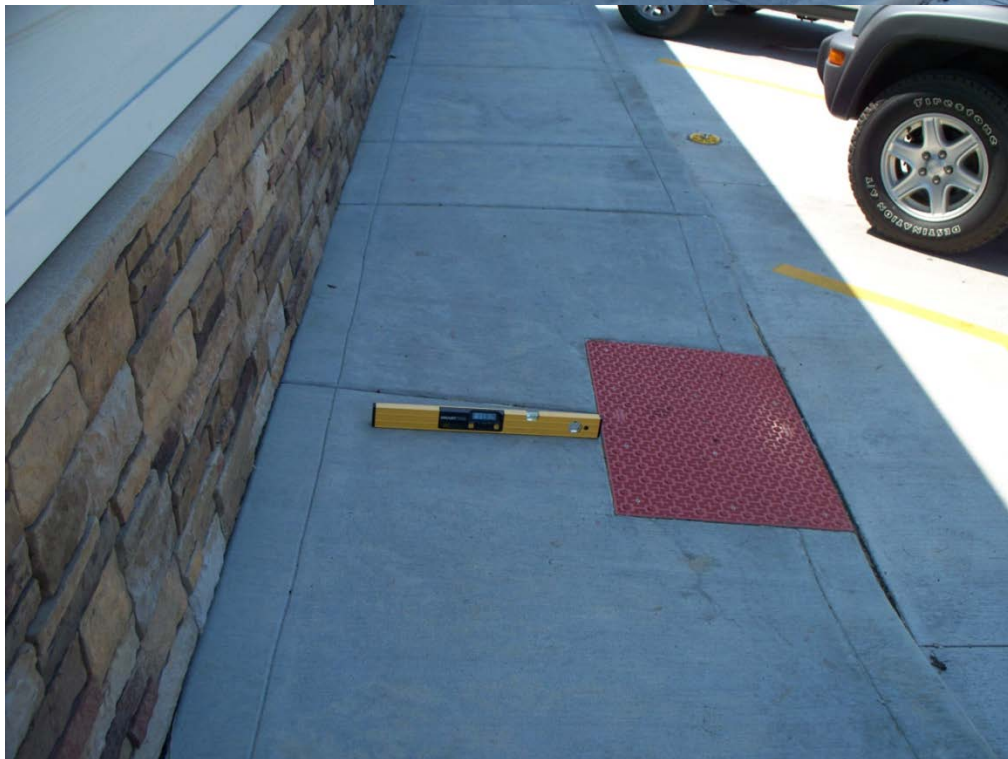
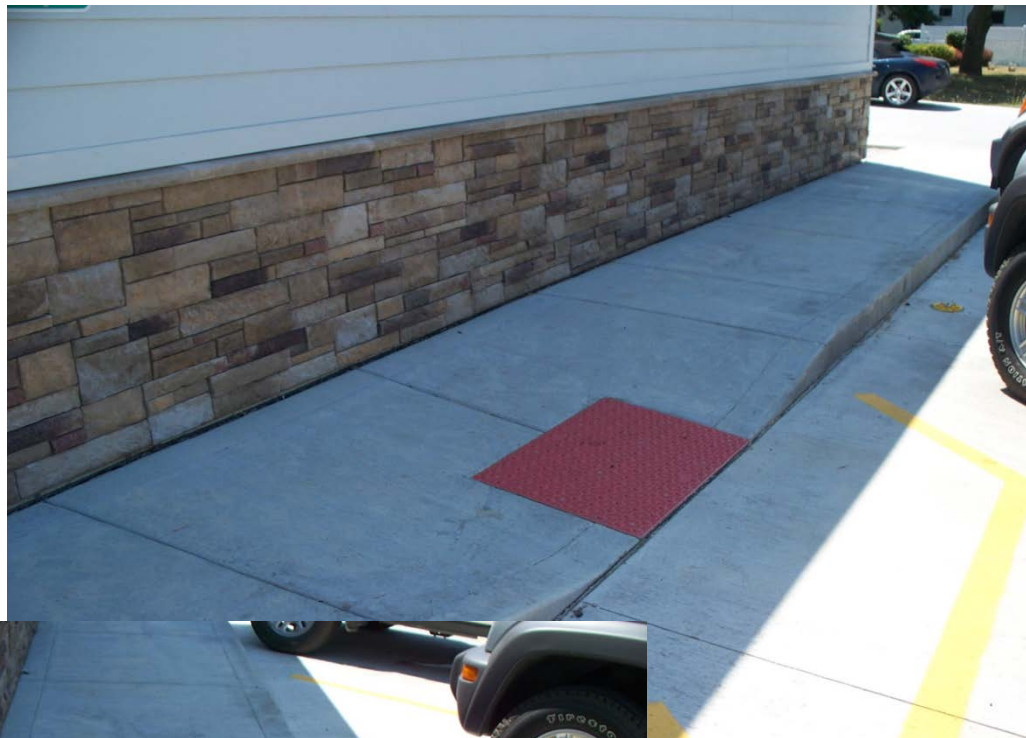

Parallel curb ramps

Parallel ramps can be used where space is limited

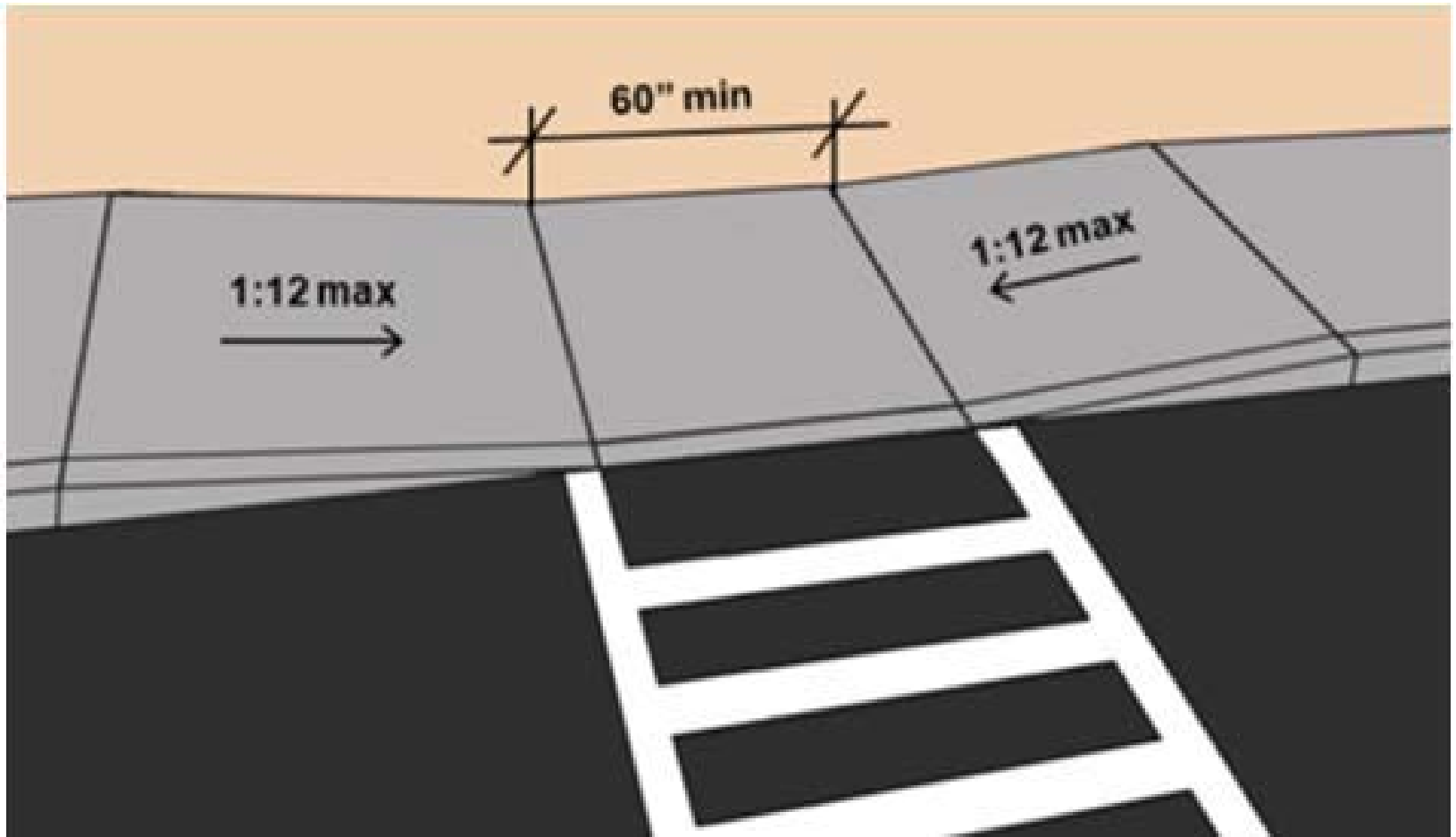

Parking



When/where are accessible parking spaces required?

- Employee or Visitor Parking Lots (IAC §400.310(c)(1))
 - Tenant/Visitor/Employee Parking
- On-Street Parking
 - No requirement for accessible parking in the IAC.
 - IDOT – Bureau of Local Roads & Streets. Accessible on-street parking covered in 41-6.04(b).
 - PROWAG – Best Practice R309
- **An accessible space must be located on the **shortest** path of travel from adjacent parking to an accessible entrance.**
 - **SPECIFICALLY, THE ACCESSIBLE SPACE IS TO BE INSTALLED IN THE CLOSEST PARKING SPACES NEAR THE ACCESSIBLE ENTRANCE.**

Alterations requiring accessible parking spaces

- **Specific Modifications of New Construction Requirements Permitted in Alterations**
 - IAC §400.510(e)(10)(C)
 - Site Improvements and Exterior Facilities:
 - All changes, improvements, or maintenance of existing parking lots including sealcoating, resurfacing, remarking, fencing, curbs, walks, and/or landscaping shall provide accessible parking spaces in accordance with Section 400.310(c). In addition, there shall be provided curb ramps as necessary to provide an accessible route to an accessible entrance.

Parking

Total Number of Parking Spaces	Min. Number of Accessible Spaces
1 to 25	1
26 to 50	2
51 to 75	3
76 to 100	4
101 to 150	5
151 to 200	6
201 to 300	7
301 to 400	8
401 to 500	9
501 to 1000	2 percent of total
1001 and over	20, plus 1 for each 100, or fraction thereof, over 1000

Scoping applies to each parking facility (ADA)

Accessible Parking Spaces

Striping, size and markings

- **Every accessible parking space shall be at least 16 feet wide.**
 - A space may consist of an 8-foot wide vehicle space and an 8-foot wide diagonally striped access aisle; or
 - A space may consist of an 11-foot wide vehicle space and a 5-foot wide diagonally striped access aisle.
 - Yellow paint is required.

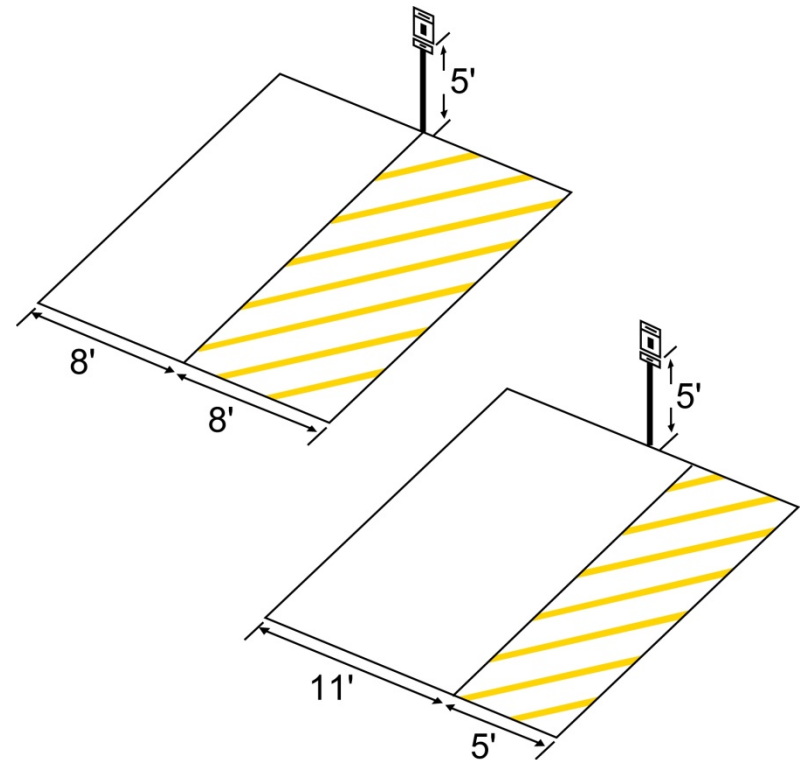

Accessible parking space & access aisle

- Parking spaces and access aisle shall be level with surface slopes not exceeding 1:50 (2%) in all directions.
 - IAC §400.310(c)(3).



ADA Standards – Clarification

- Width measurements (parking space and access aisle)
 - Measure from the centerline of the pavement markings. §502.1 Exception.
 - Exception: Spaces are not adjacent to another space or access aisle – measurement can include full width of the lines. §502.1 Exception.
- Angled parking – access aisle on the passenger side of the parking space - §502.3.4
- Cannot overlap the vehicular way

ADA Parking Signs (Blue signs incorrect in IL)

Sign height = 60" (§502.6)

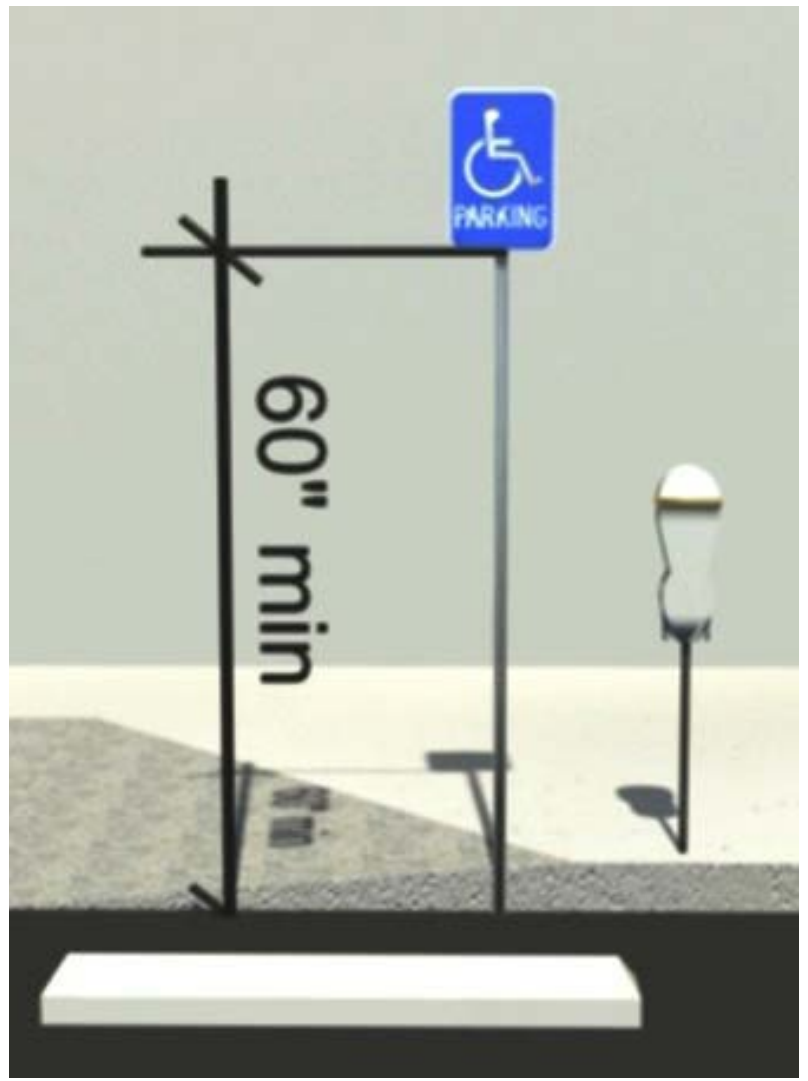



Illinois - accessible parking signs



- Accessible space must be designated by an R7-8 sign
 - Reserved Parking
 - International Symbol of Accessibility
- Sign location
 - 5' from front of space
 - 5' from ground to bottom of sign (ADA § 502.6)
- Arrow is optional
- R7-I101 Fine Sign
 - Minimum \$250 Fine
 - A municipality by ordinance can set a higher fine amount up to \$350



Attorney General Opinion – 12-003

Conclusion:

Under the Americans with Disabilities Act of 1990, a State agency may need to provide an assigned parking space to an employee with a disability as a reasonable accommodation to ensure that the employee may access the workplace and enjoy the parking benefits provided to employees without disabilities. Ultimately, whether an assigned parking space would be a reasonable accommodation requires a case-by-case analysis. But if an agency assigns a parking space to an employee with a disability as a reasonable accommodation, it cannot also count that space to meet the requirements of the Illinois Accessibility Code. The Illinois Accessibility Code mandates that agencies provide a specific number of accessible parking spaces, and the Illinois Vehicle Code, in turn, provides that those spaces must be available to any individual with an accessible parking permit. Based on these provisions, it is my opinion that the required accessible parking spaces may not be designated for employee-only use. Rather, if assigning parking spaces to employees with disabilities causes a State agency's number of accessible parking spaces to fall below the minimum required by the Illinois Accessibility Code, then the agency must designate additional, properly marked accessible parking spaces for general use by individuals with disabilities.

Operable Parts

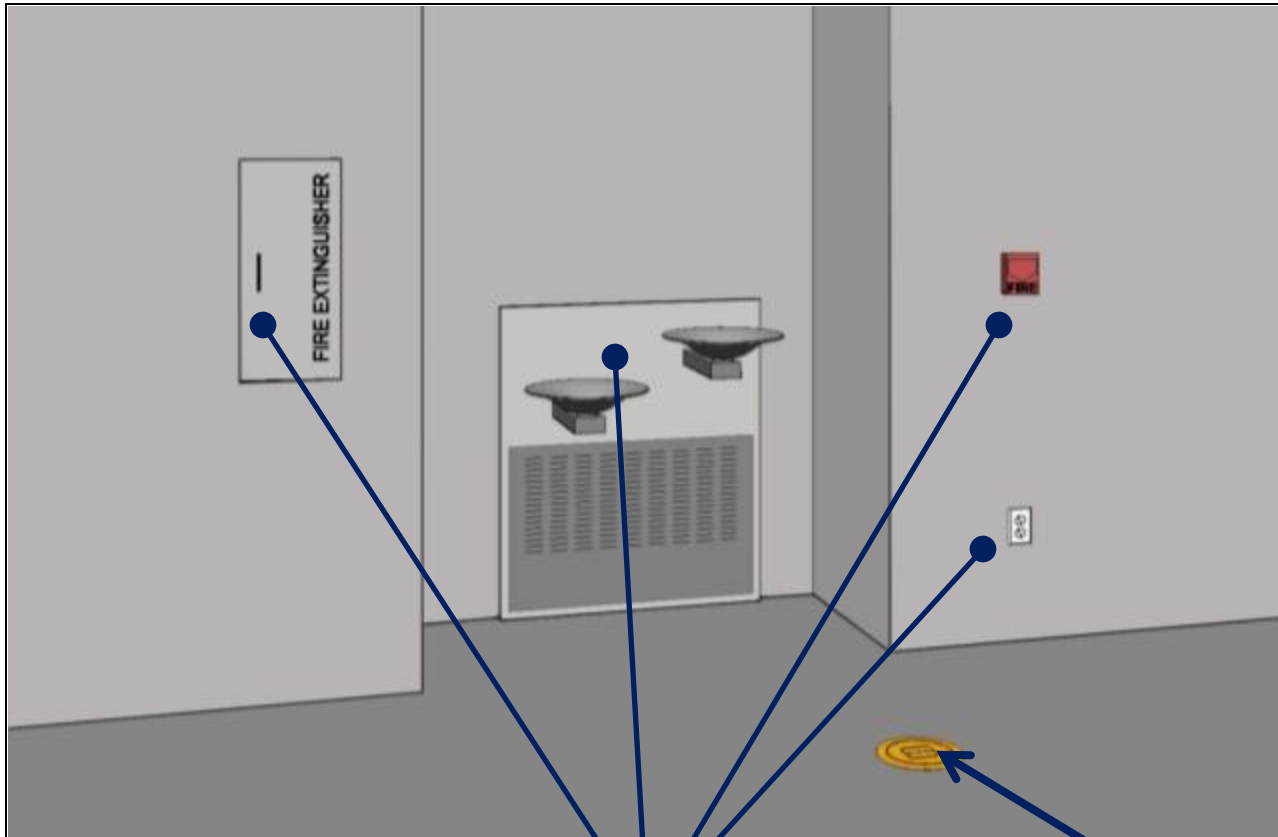

Exempt: floor receptacles

Examples of Operable Parts

Operable Parts

Requirements of an Operable Part:

- Operability
- Reach range
- Clear floor space
 - 30" x 48" minimum
 - Level 1:50
- Connected by accessible route





Operability

1 hand operation

No tight grasping, pinching, or twisting of wrist

5 lbf maximum (ADA §309.4 exception – gas pump nozzles)

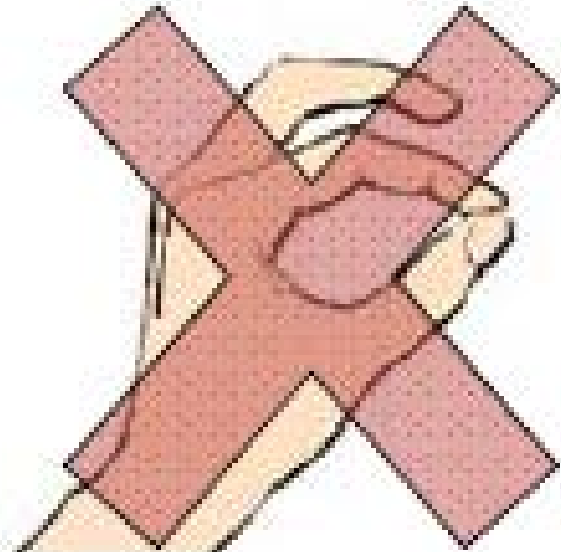



Operability

Closed fist operation = good, but not mandatory



Many other types comply (e.g., U-shaped pulls)

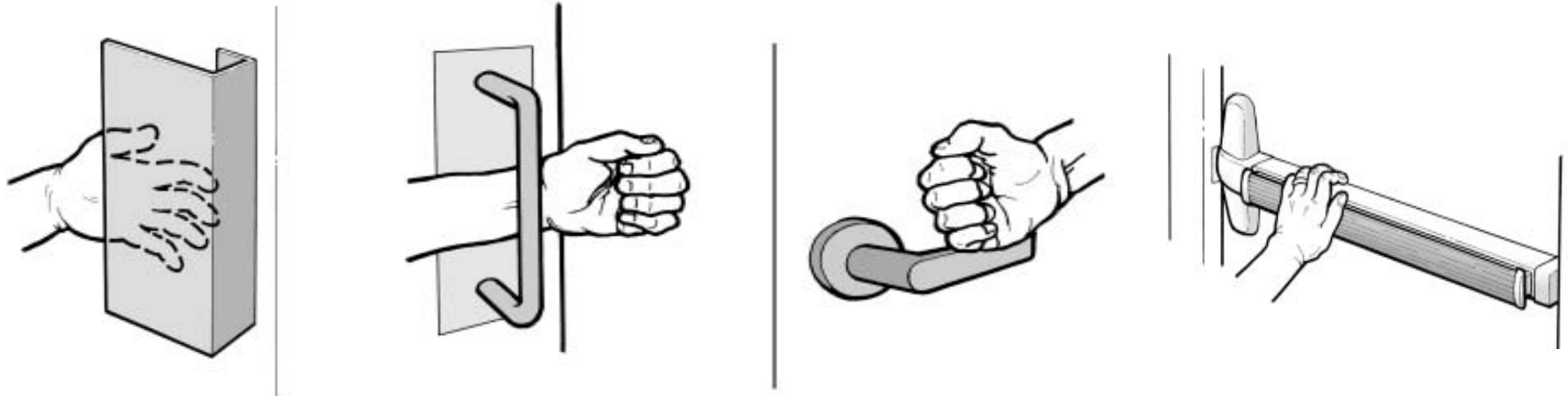

Examples of handles and hardware that can be used without tight grasping, pinching, or twisting.



Reach Ranges

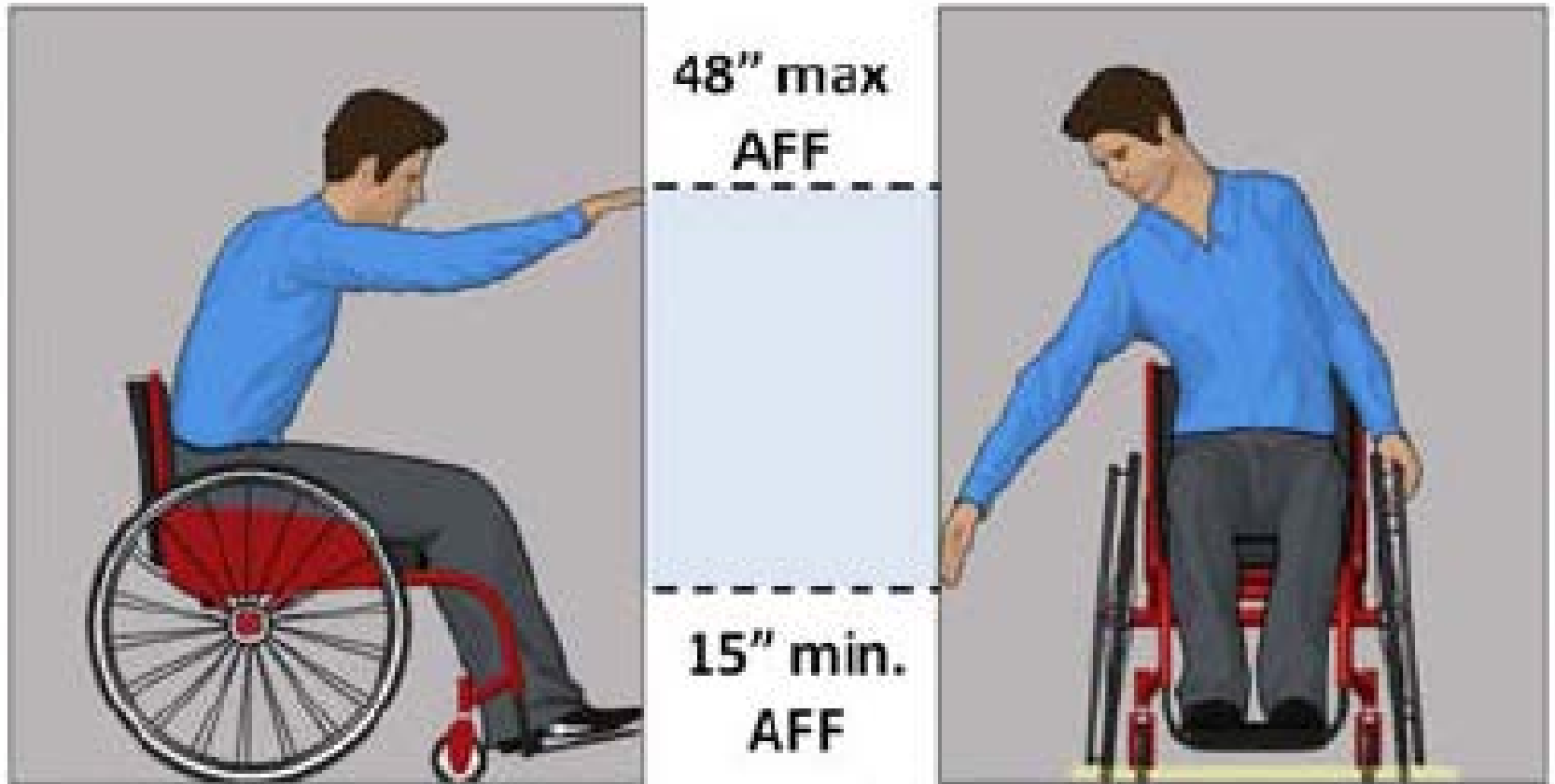

Unobstructed forward and side reaches

Forward Reach (Obstructed)

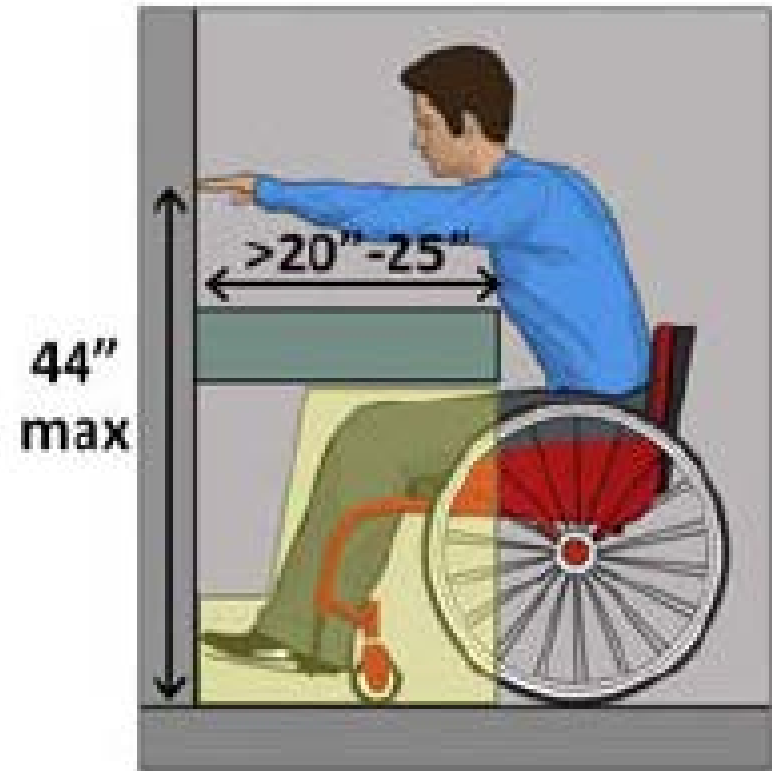
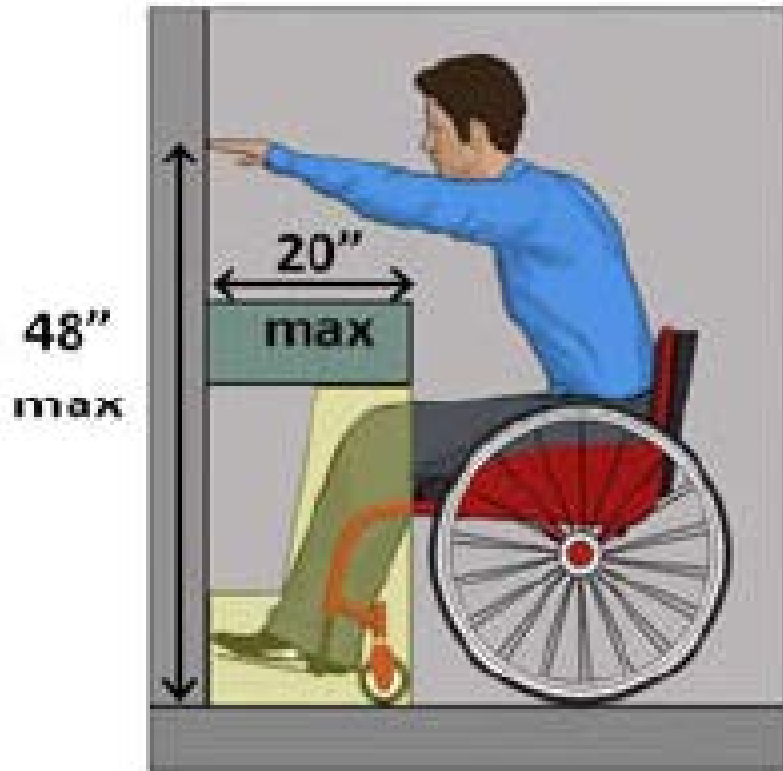

Obstructed reach: 44" maximum if reach depth exceeds 20"

Side Reach (Obstructed)

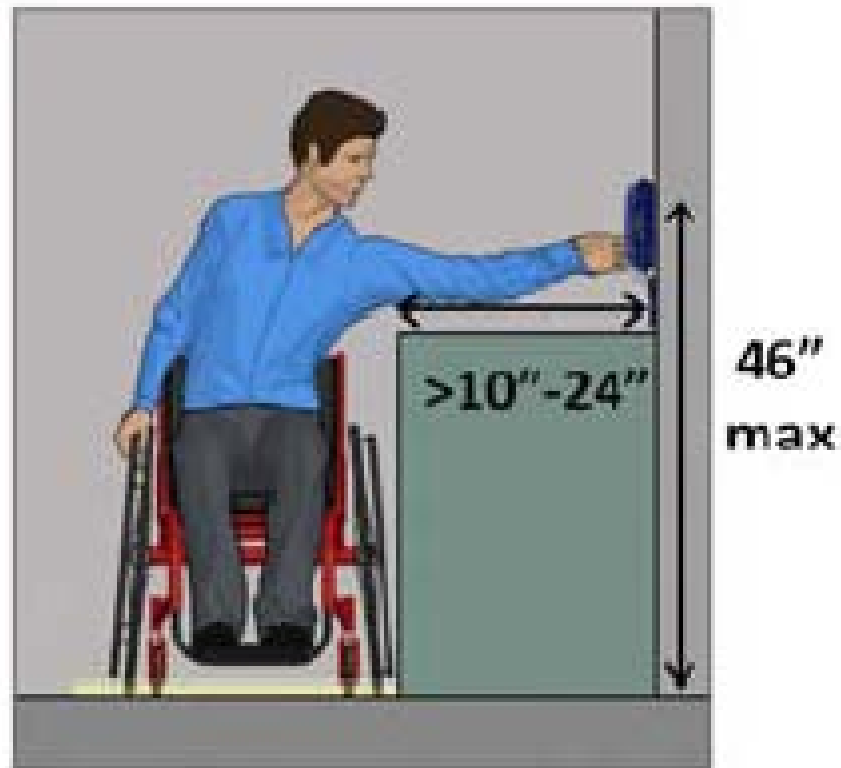
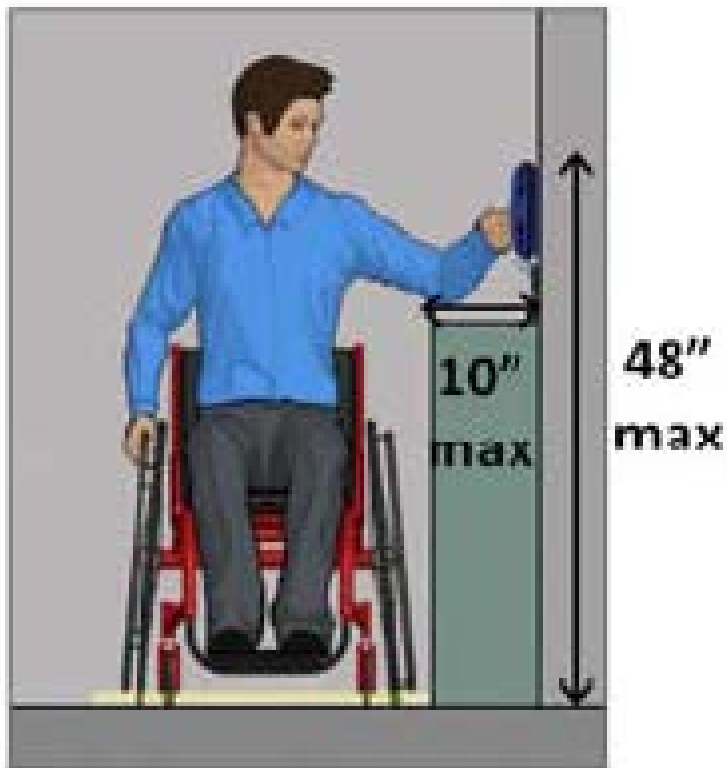

Obstructed reach: 46" maximum if reach depth exceeds 10"

Clear Floor or Ground Space

Clear floor/ground space = 30" x 48" minimum
Level 1:50

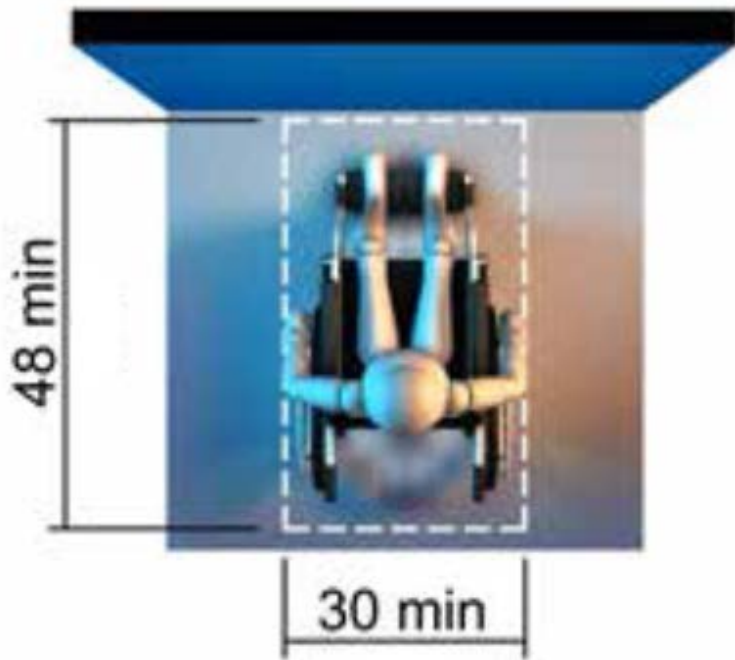

forward

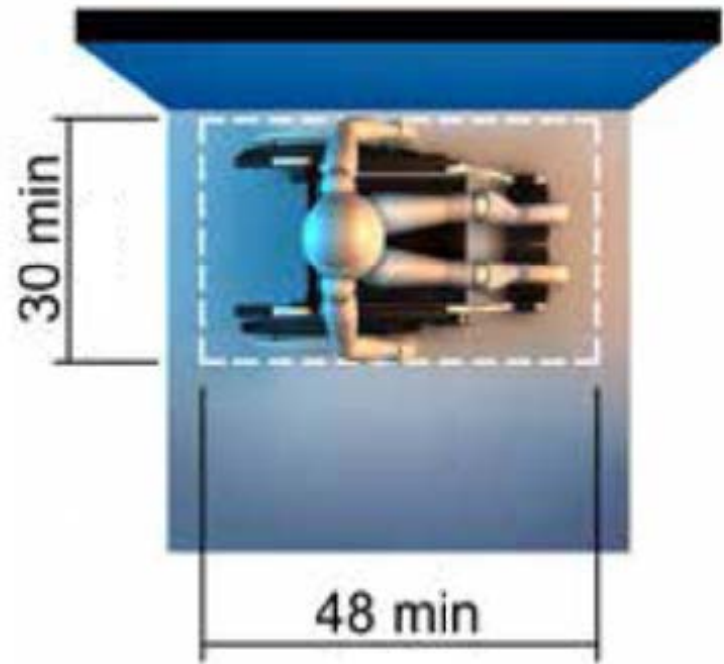

parallel

Protruding Objects

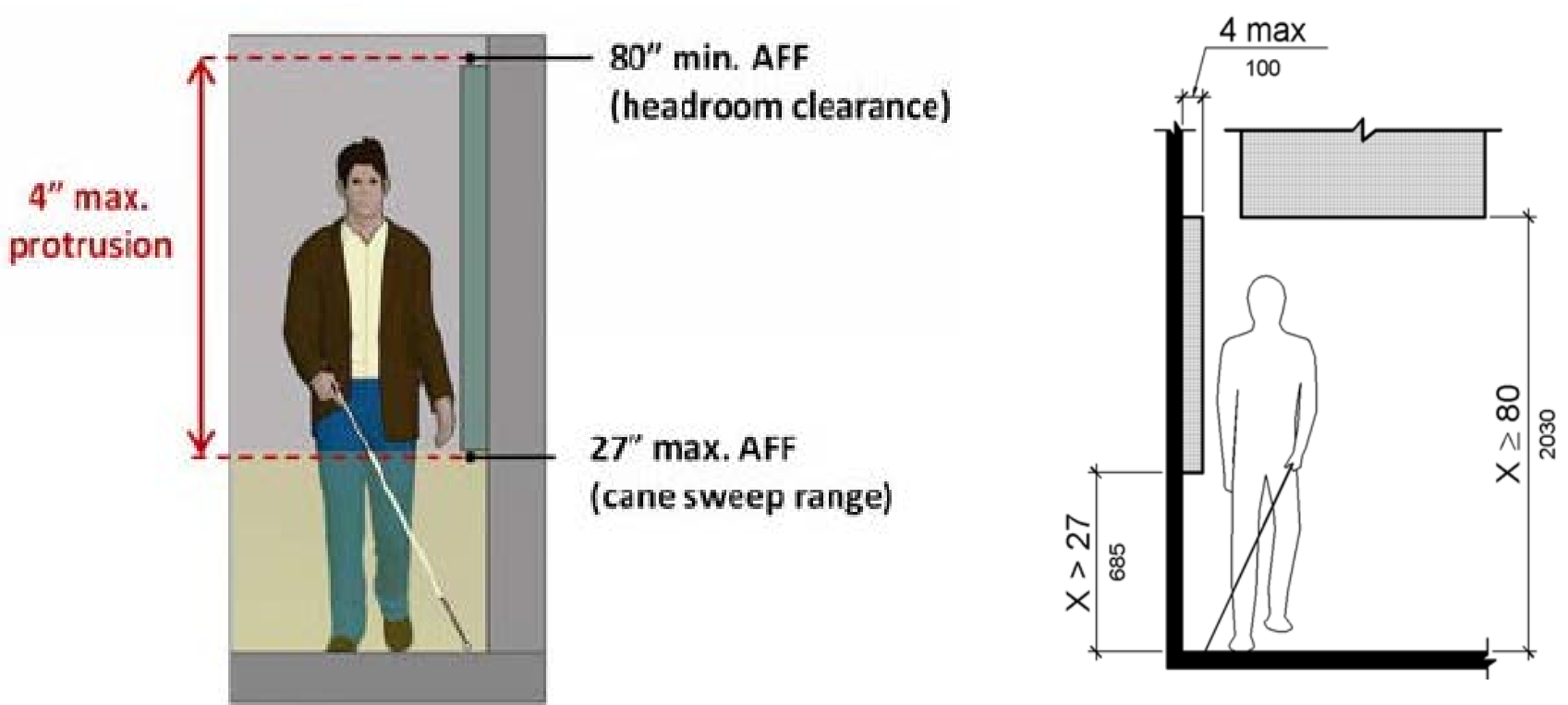

Protrusion limits apply to all areas of circulation – not limited to accessible routes.



If the bottom edge of a drinking fountain is more than 27 inches above the finished floor it shall protrude 4 inches maximum into the circulation path. §307.2



- Alcove or wing wall removes the drinking fountain from the circulation path.





JAN 19 2007



Entrances

At least 50% of all public entrances shall be accessible with the IAC§400.310(k)(2)(A).

At least 60% of public entrances shall comply with ADA §206.4.1.

- Where provided to gain admittance to a building or facility or restricted area within a building or facility – ADA §230.1
- Communication devices must have both visual and audible signals –ADA §708.2





Entrances/Doors

- Automatic/power assist doors are not required
- Floor or ground area within the clearances shall be level (2% or less) and clear.
- Width
 - 32"
- Door opening force
 - Exterior doors = 8.5 lbf (IAC)
 - Interior doors = 5 lbf
- Thresholds
 - ½" maximum (bevel between ¼" and ½")
- Maneuvering clearances have to be clear of all obstructions (trash cans, flower pots, ash trays, etc.)



Maneuvering Clearances

Minimum space for positioning/maneuvering at doors

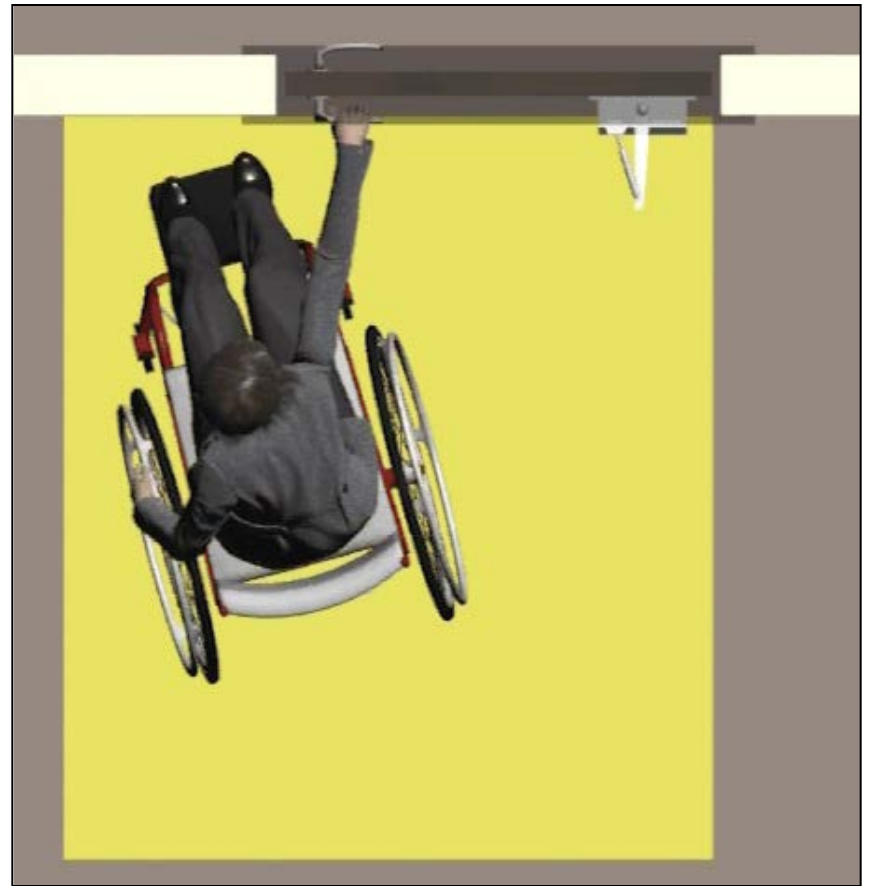

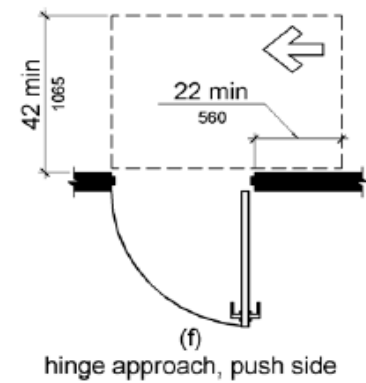
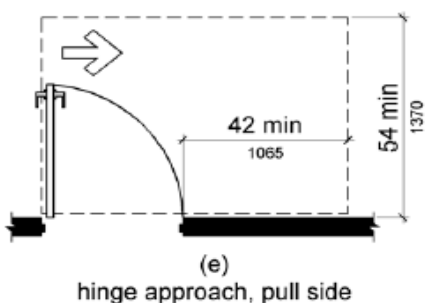
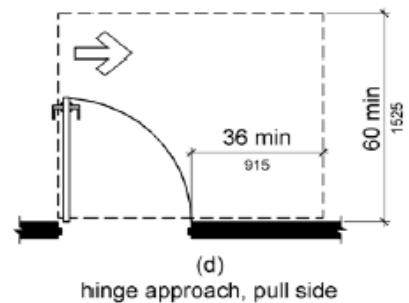
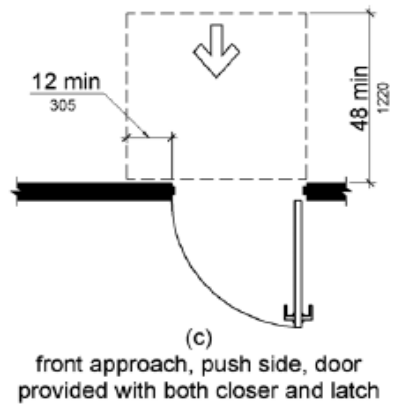
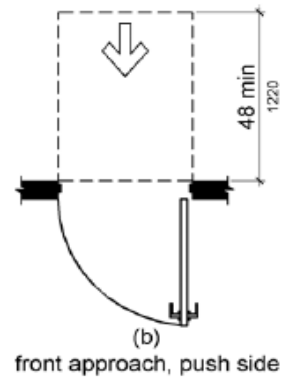
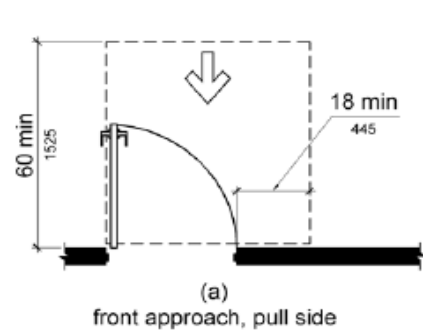

ADA Figure 404.2.4.1 Maneuvering Clearances at Manual Swinging Doors and Gates

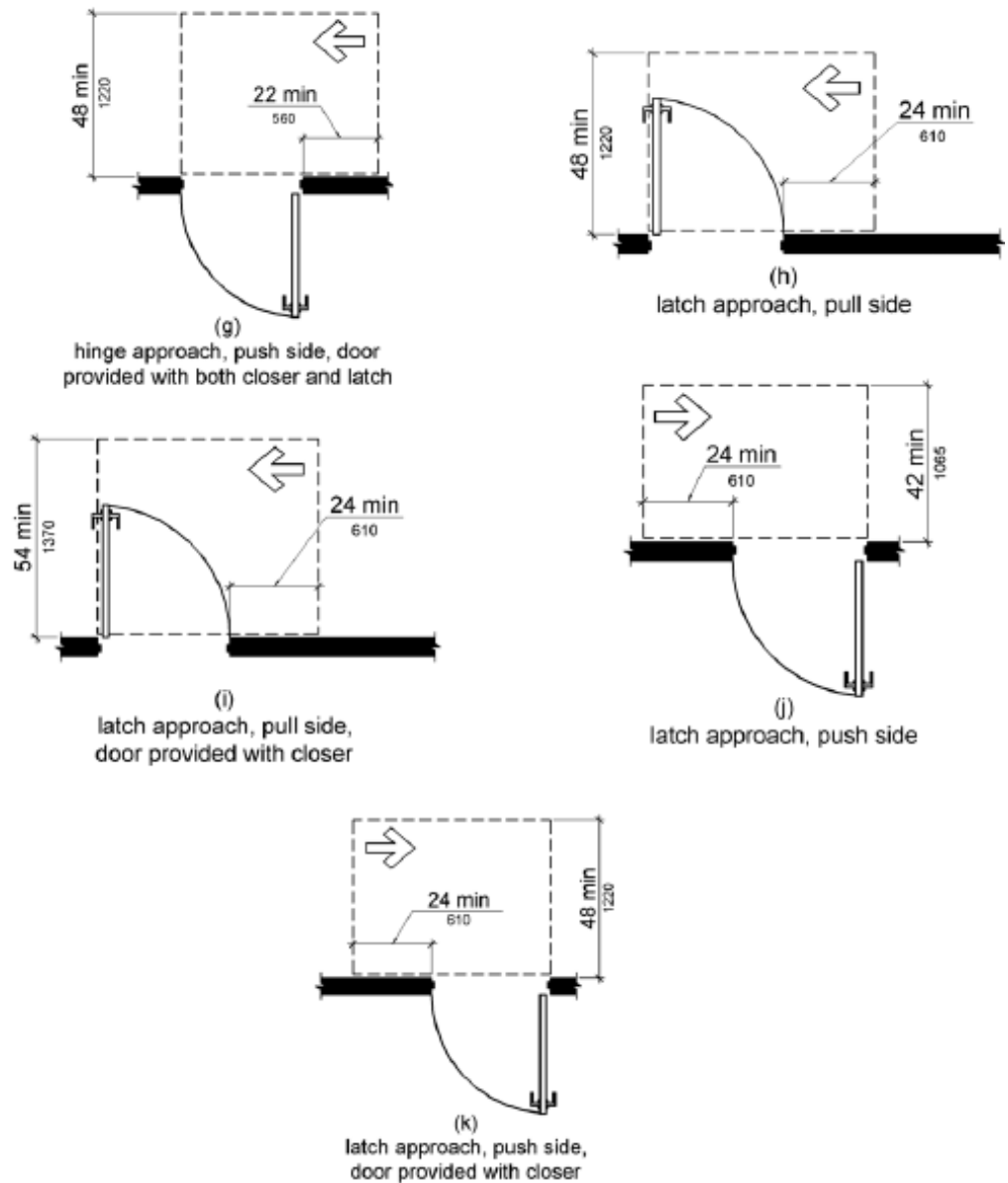

Figure 404.2.4.1
Maneuvering Clearances at Manual Swinging Doors and Gates

Table 404.2.4.1 Maneuvering Clearances at Manual Swinging Doors and Gates

Type of Use		Minimum Maneuvering Clearance	
Approach Direction	Door or Gate Side	Perpendicular to Doorway	Parallel to Doorway (beyond latch side unless noted)
From front	Pull	60 inches (1525 mm)	18 inches (455 mm)
From front	Push	48 inches (1220 mm)	0 inches (0 mm) ¹
From hinge side	Pull	60 inches (1525 mm)	36 inches (915 mm)
From hinge side	Pull	54 inches (1370 mm)	42 inches (1065 mm)
From hinge side	Push	42 inches (1065 mm) ²	22 inches (560 mm) ³
From latch side	Pull	48 inches (1220 mm) ⁴	24 inches (610 mm)
From latch side	Push	42 inches (1065 mm) ⁴	24 inches (610 mm)

1. Add 12 inches (305 mm) if closer and latch are provided.
2. Add 6 inches (150 mm) if closer and latch are provided.
3. Beyond hinge side.
4. Add 6 inches (150 mm) if closer is provided.

Maneuvering Clearance

- Accommodates all types of mobility aids





JAN 19 2007

Doors in Series

- Requirement applies in all cases (same direction, in-swinging, out-swinging)

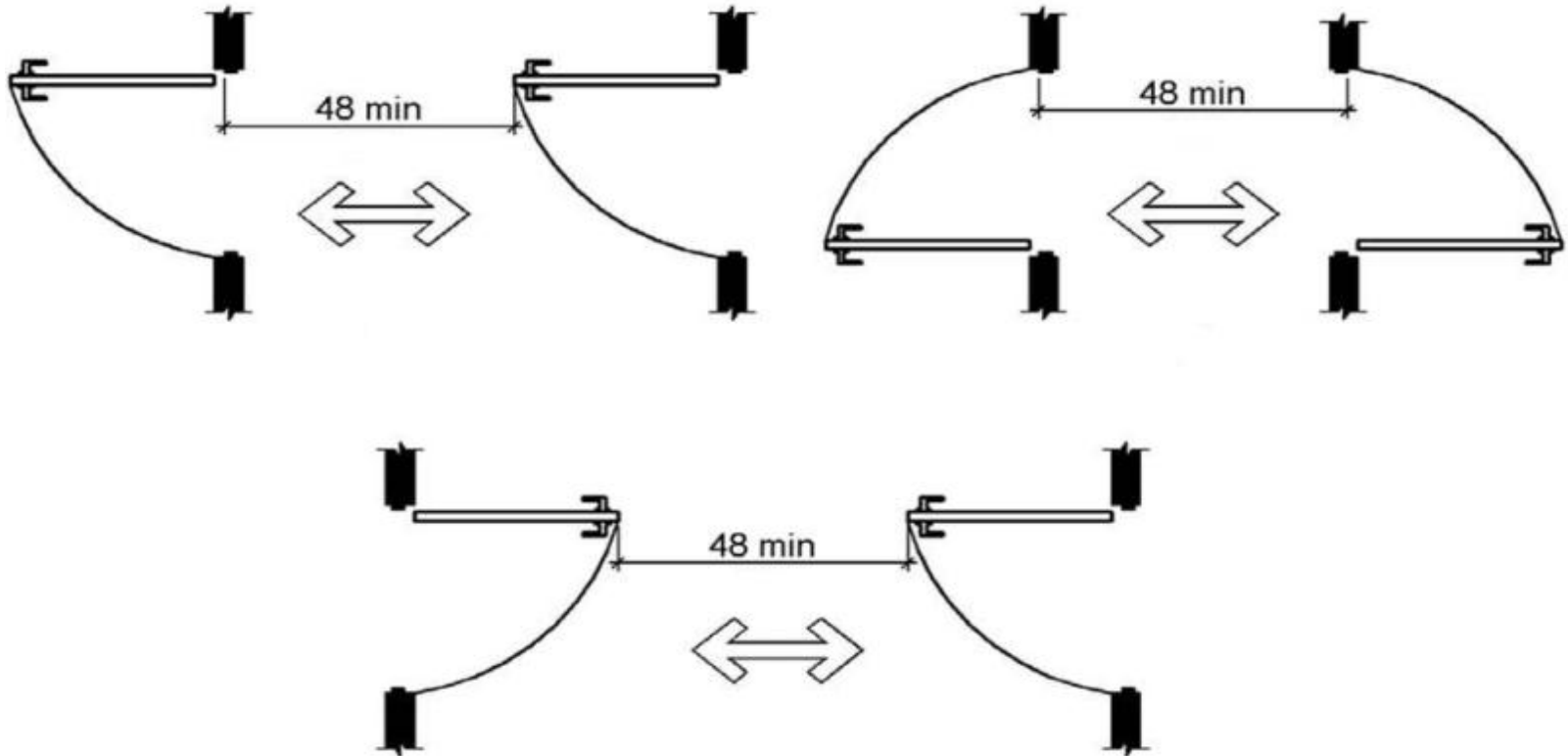

Ramps

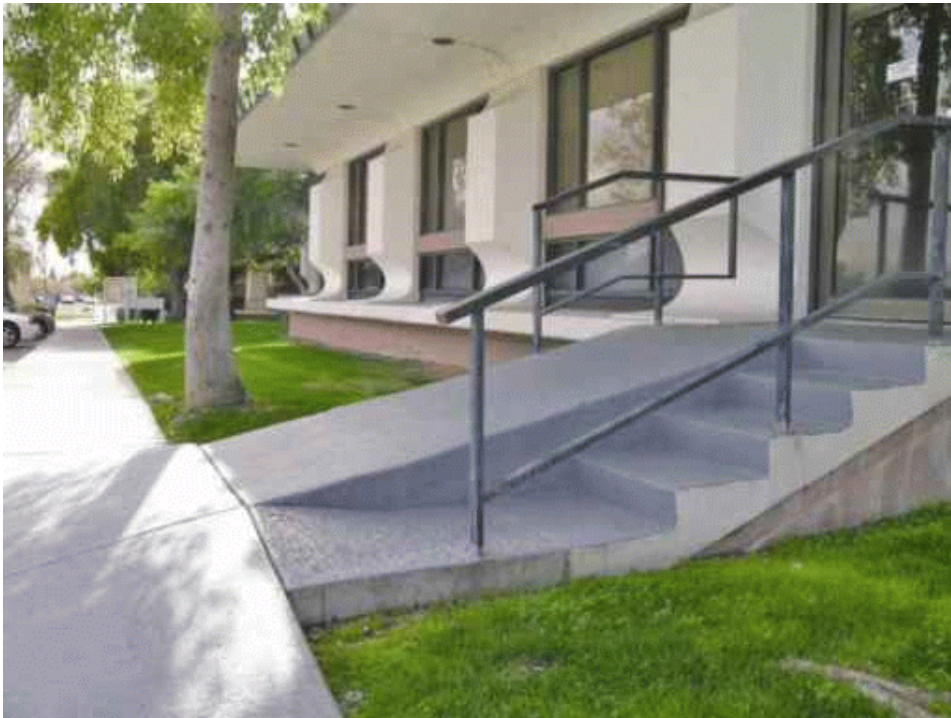

Ramps

- Ramp – Any part of an accessible route with a slope greater than 1:20 (5%).
 - Slope and rise – maximum slope of 1:12 – every inch of rise requires a foot of run.
 - Cross slope – no greater than 1:50 (2%).
 - Width – minimum clear width of 36”.
 - Maximum rise of 30”
 - Landings – level landings at top and bottom of each ramp and each ramp run.
 - Handrails – provide on both sides if rise greater than 6” or horizontal projection greater than 72”.
 - Edge protection – Ramps and landings with drop-offs shall have curbs, walls, railings, or projecting surfaces that prevent people from slipping off the ramp.
 - Surface – stable, firm and slip resistant.



Sales and Service Counters

- Sales/Service counter
 - IAC §400.310 (w); ADA §227.3 and §904.4
 - Parallel or forward approach
 - Length and height of accessible portion of the counter
 - Forward approach must have knee and toe space



Queues and Waiting Lines



Drinking Fountains

- Hi-lo (or other accessible unit for each disability)
- Clear Floor Space
 - Forward approach
 - Centered on the unit
 - Knee and toe clearances
- Operable Parts
- Spout Height = 36"
- Height for standing units = 38" – 43" (ADA§602.7)

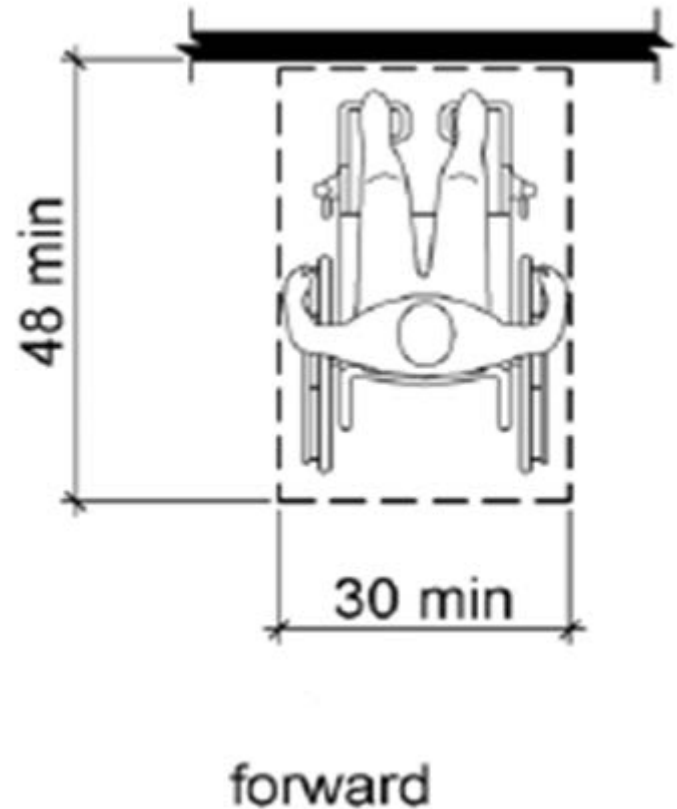



Toilet and Bathing Rooms

- Toilet rooms
 - IAC - All have to comply (unless adaptable)
- Bathing Rooms
 - IAC – One for each gender §400.310 (o)(1)



Private Toilet Rooms

“Adaptability” permitted:

- private (not common) use
- single occupant
- accessed only through private office

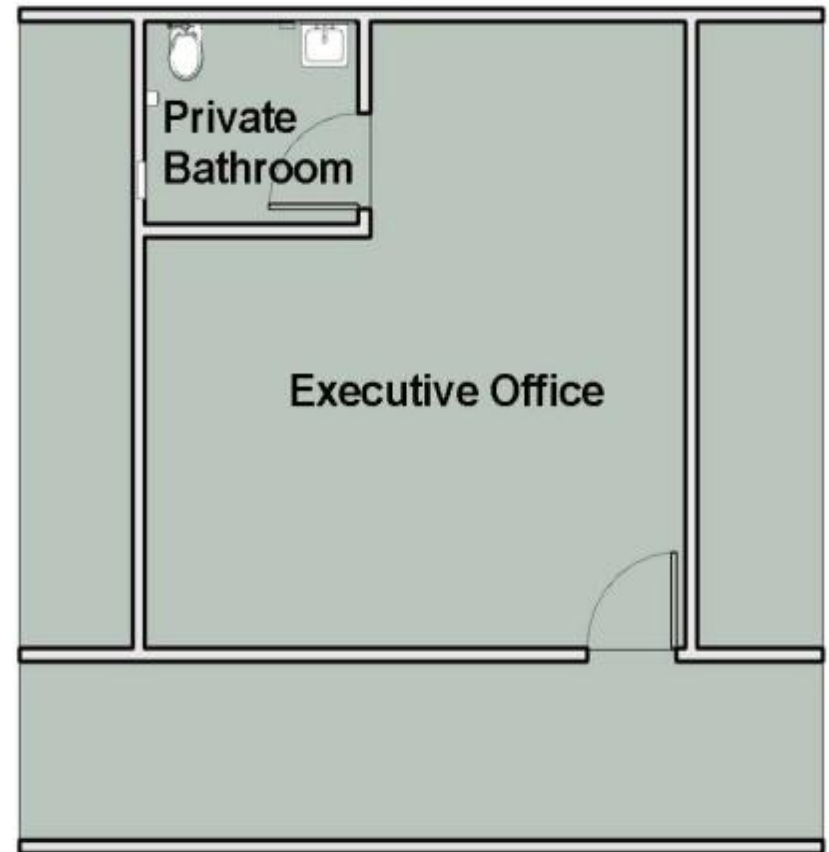

Toilet Room Operable Parts



Examples of Operable Parts



Lavatories

- Clear floor space (30" x 48")
- Knee/toe clearances
- Height
 - 34" maximum (rim or counter)
- Faucet & controls
- Dispensers
- Pipes
- Mirror height

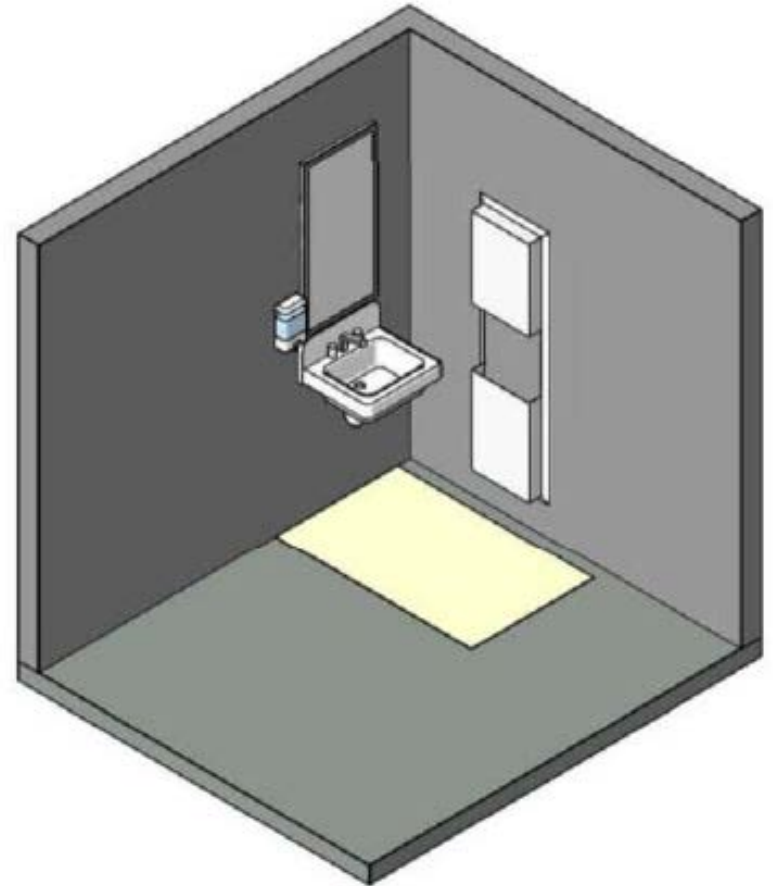

Lavatories – Knee & Toe Clearances

- Full depth: 17" – 19"
- Measured from leading edge of lavatory

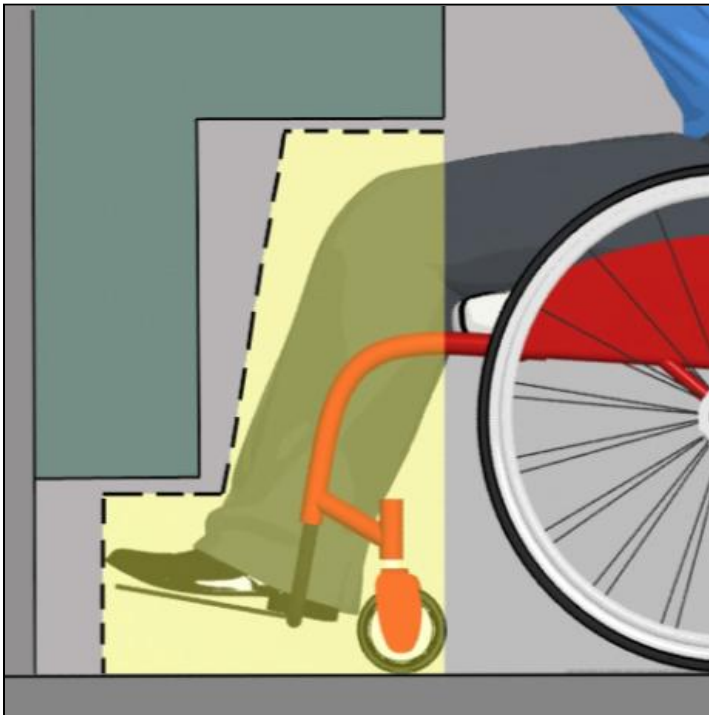

- Knee clearance
 - Height: 27" minimum
 - Depth: 8" minimum

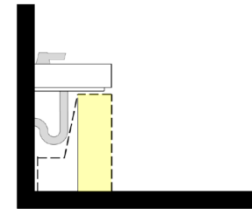

- Toe clearance
 - Height: 9" minimum
 - Depth: 6" maximum

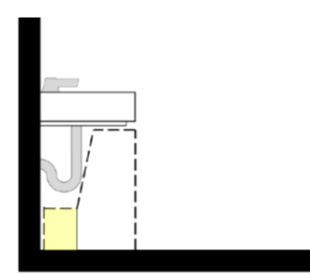

- Pedestal sinks are not allowed by IAC & ADA.
- Forward approach, knee and toe clearance to accessible sinks are required.
- IAC - § 400.310(n)(7)(C)
- ADA- § 606.2

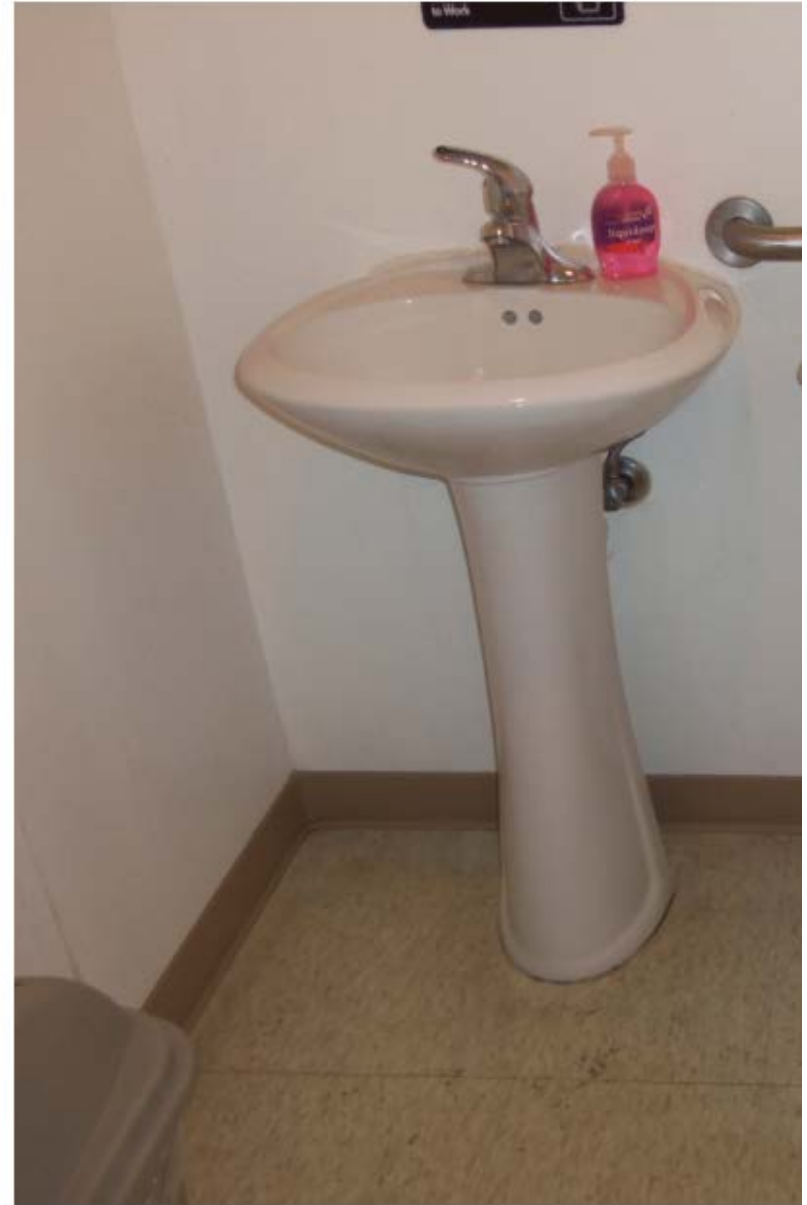

Toilet Rooms

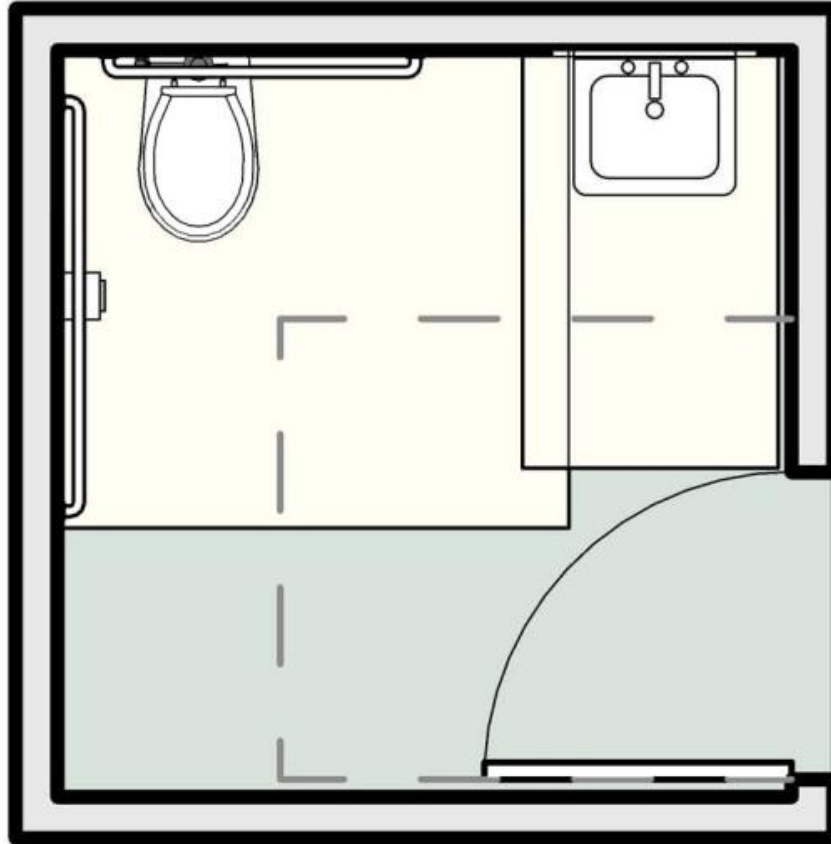

Door man. clearance; swing outside fixture clearances

Toilet Rooms

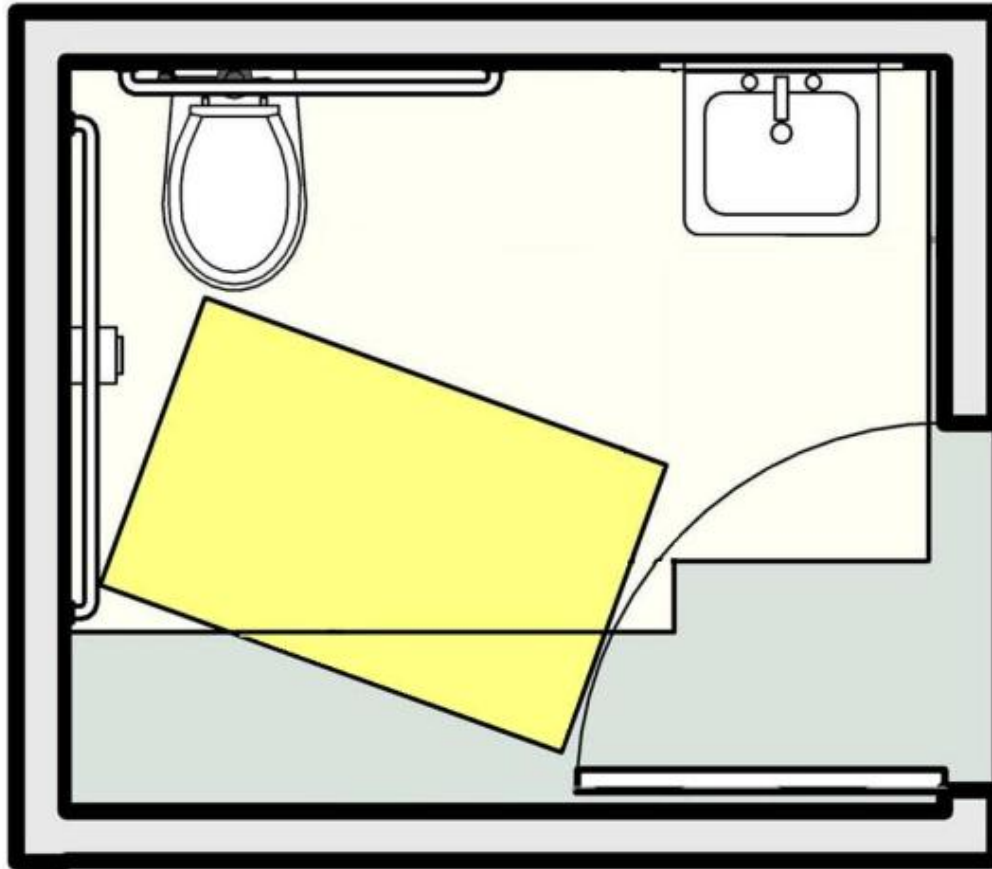

Doors can swing into fixture clearances if clear floor space (30" x 48" min.) provided outside swing

Toilet Rooms

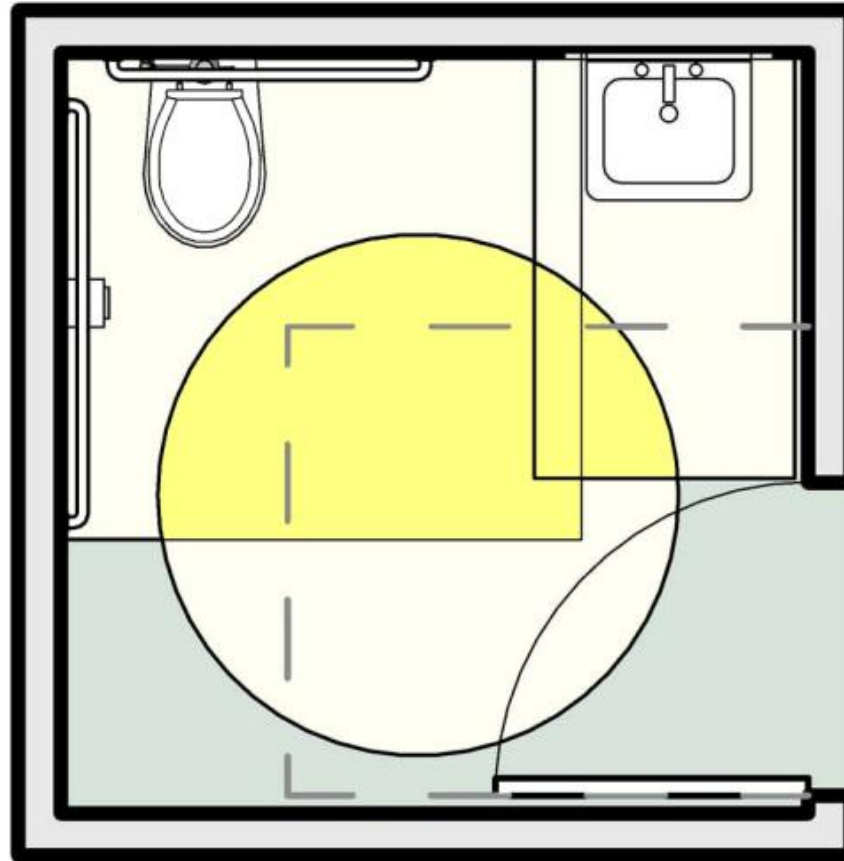

Turning space can overlap fixture & door clearances;
door can swing into turning space

Toilet Stalls

- 6 or more stalls
 - Accessible stall, and;
 - Alternate (ambulatory) stall
 - 36" wide, outward swinging self-closing door and parallel grab bars
- Door hardware
- Toilet paper dispensers
 - Dispensers that do not permit continuous paper flow shall not be used.
- Coat hanger height
 - Reach ranges apply

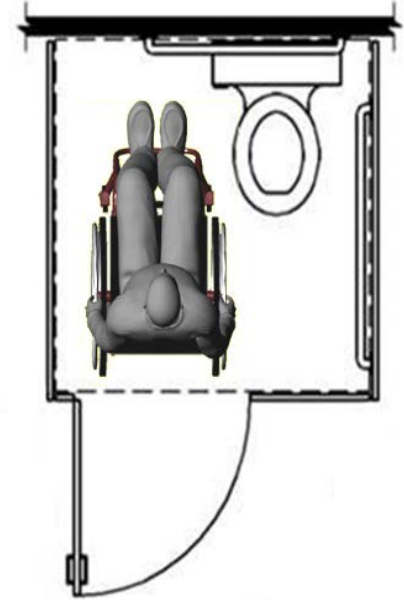

Toilet Stalls

- Size of accessible stalls

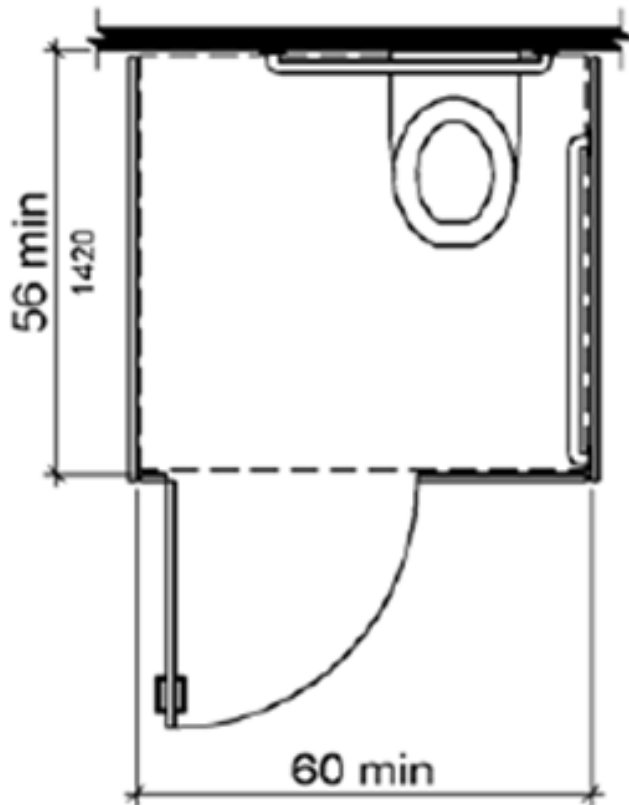

Wall hung

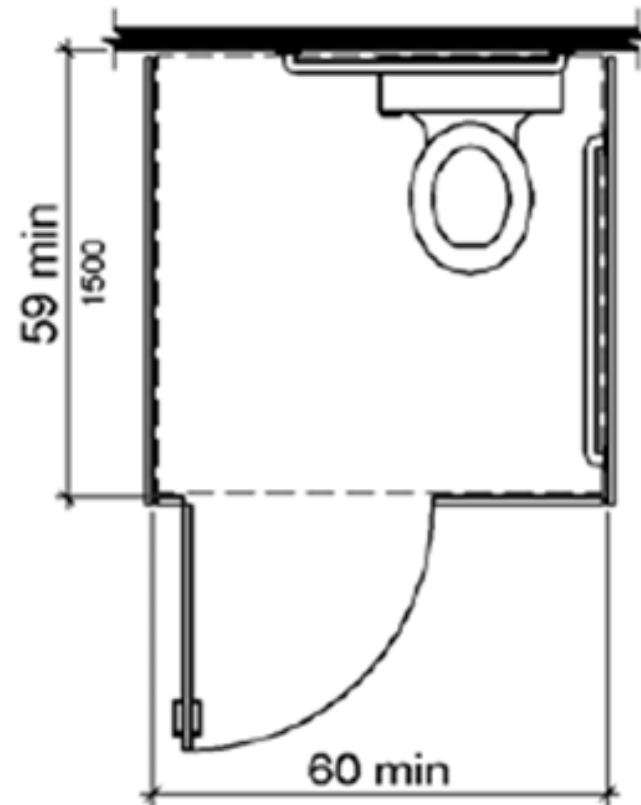

Floor mounted

Toilet Stalls: End of Row

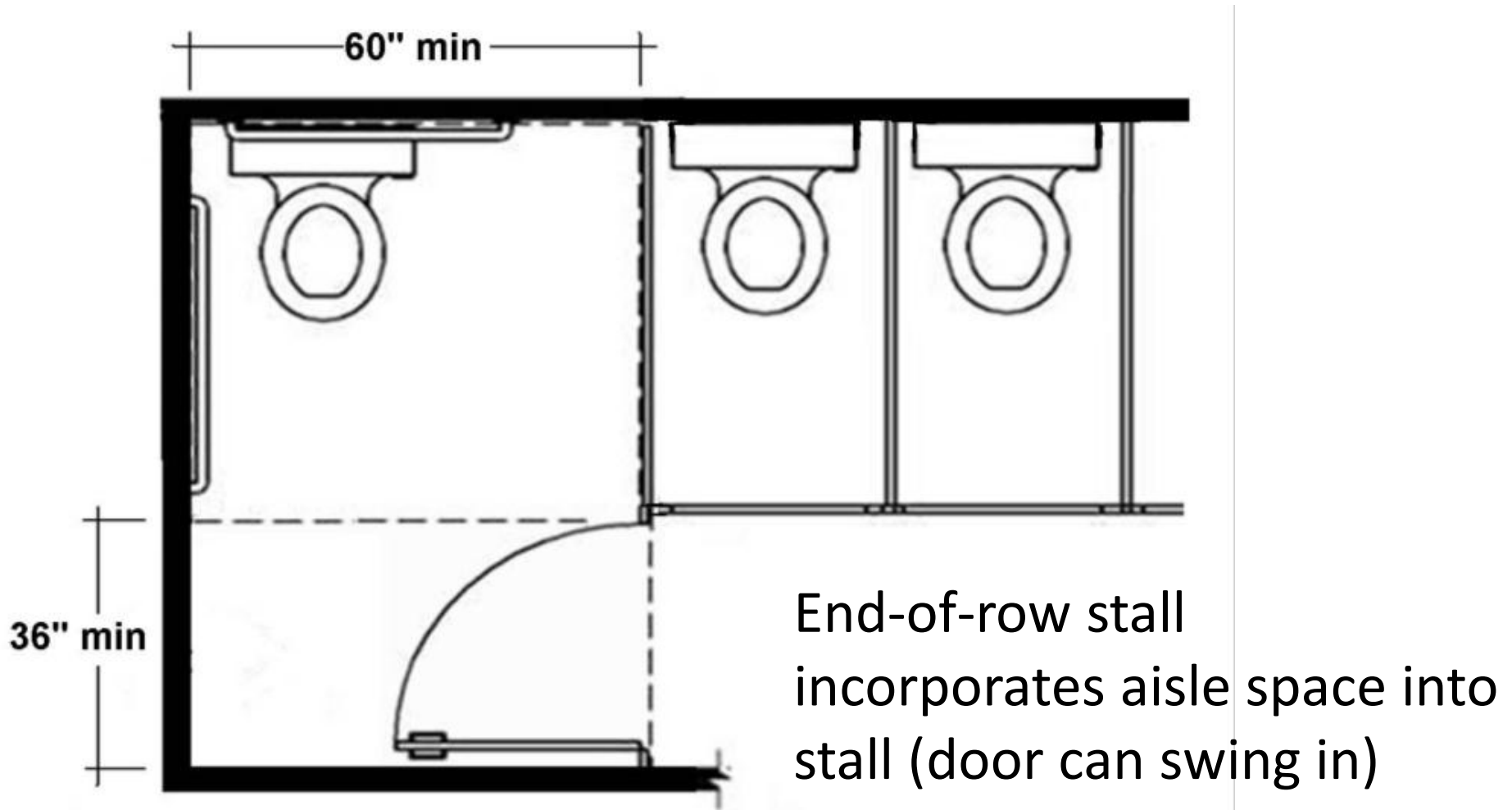

Grab Bars

Rear grab bars

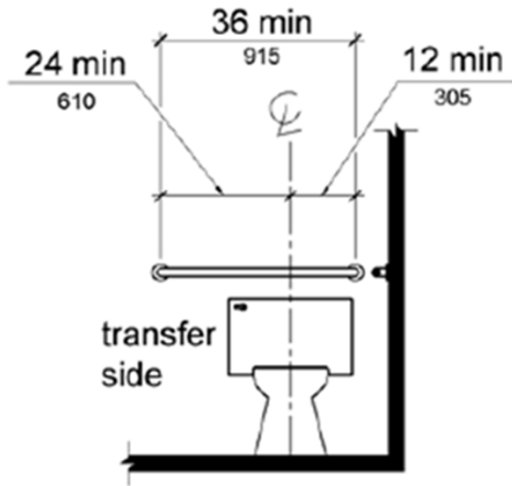

Side grab bars

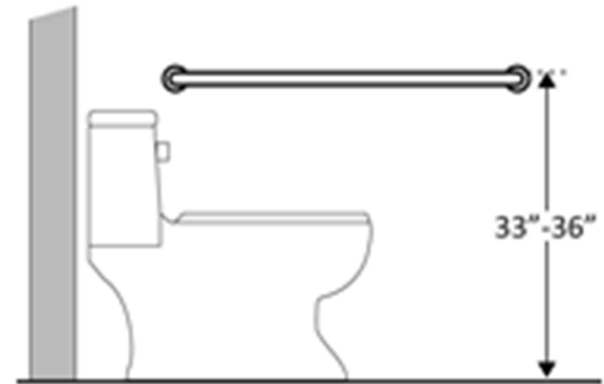
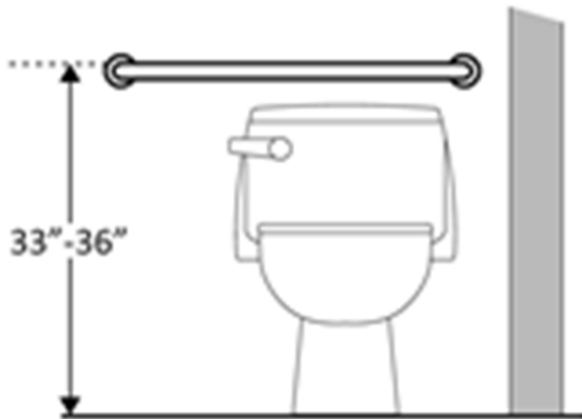
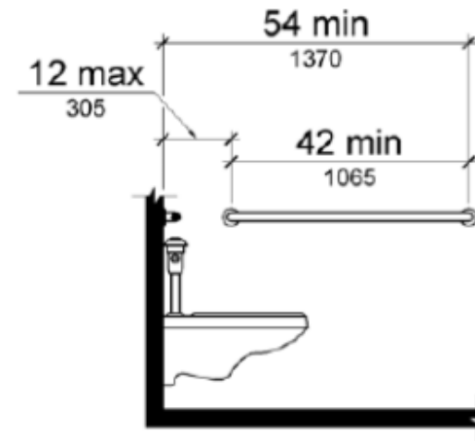





TP Dispenser

- Dispenser location
 - 7 " min. to 9" max. from front of water closet measured to centerline of the dispenser.
 - Outlet of dispenser = 15" min. to 48 max. above floor.
 - Do not locate behind the grab bar.

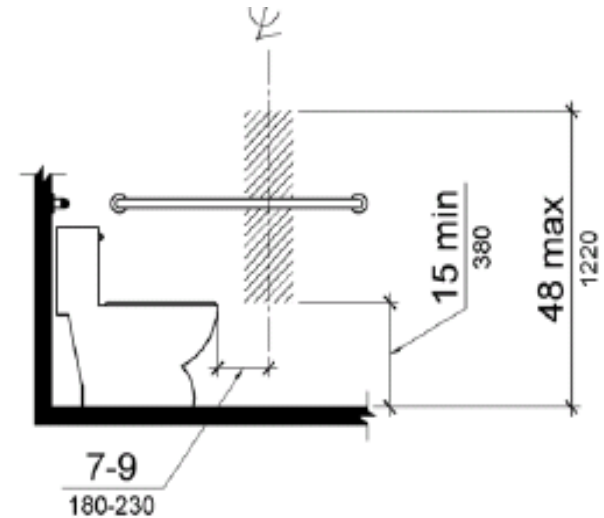
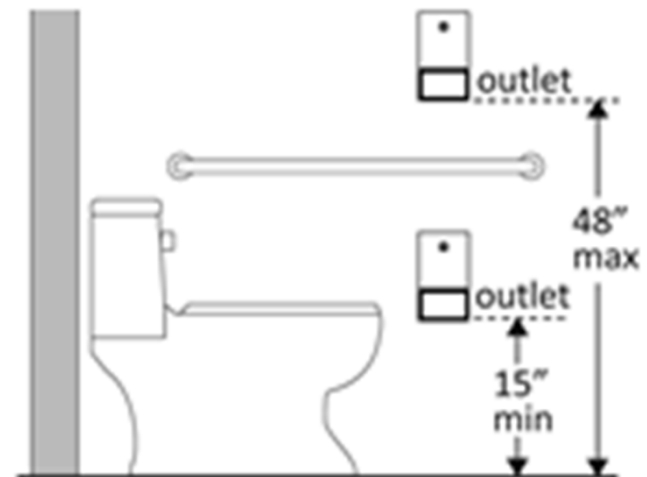
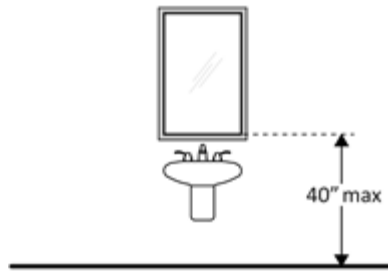

Figure 604.7
Dispenser Outlet Location



Mirrors

- Bottom edge of the reflecting surface = 40" maximum



- Mirrors not located above lavatories or countertops = 35" maximum. ADA § 603.3.

Signage

- Install accessible signs on the wall adjacent to the latch side of the door.



IAC §400.310 (u)(5)

Tactile Signs: Location

- New ADA Standards:
- 48" – 60" high measured to character baseline (instead of 60" centerline)

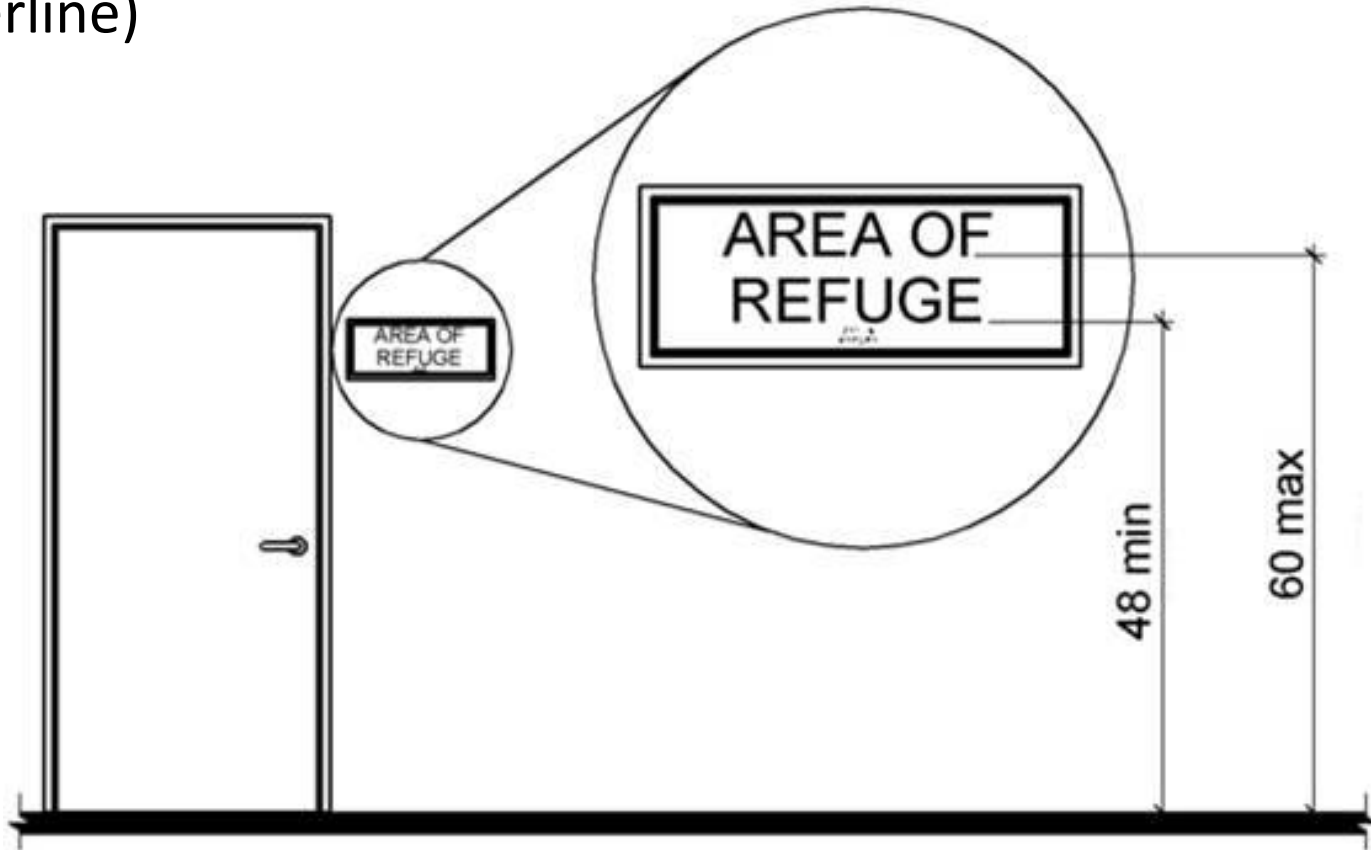

Pictograms

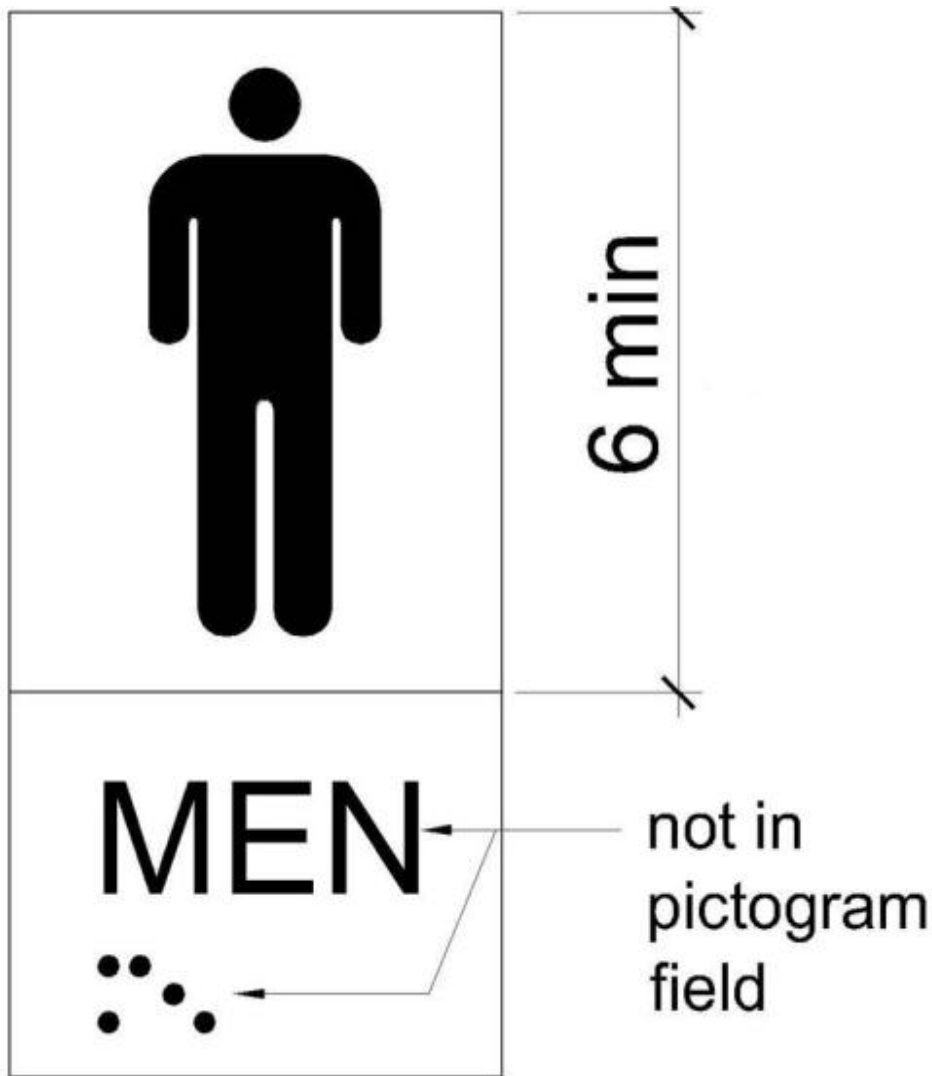

- Pictogram field height is at 6" minimum.
- Contrast with either light pictogram on dark field or dark pictogram on light field.
- Text description directly below the pictogram field.

Contrast

- Light-on dark or dark-on-light
- Contrast values not specified (the higher the better)



Contrast



Contrast

Contrast

- Examples of poor contrast



Contrast



Contrast

Character Style (ADA)

- New standards specify “conventional form”
- Prohibited by ADA (§703 .5.3):
 - *Italic* *Oblique* *script*
 - **HIGHLY DECORATIVE**
 - **or other** *unusual forms*

Assistive Listening Systems

IAC – Auditorium and Assembly Areas §400.320(a)(6-8)

ADA - Required where:

- audible communication = integral to use of the space and
- audio amplification
- Courtrooms

Not triggered by fixed seating or occupant load

New ADA technical criteria (sound pressure level, signal-to-noise ratio, peak clipping level)



ADA §219 & §706

ADA Information & Assistance

- Great Lakes ADA Center
University of Illinois at Chicago
Institute on Disability & Human Development (MC 728)
1640 West Roosevelt Road, Room 405
Chicago, IL 60608
800-949-4232 (V/TTY)
312-413-1856 (Fax)
<http://www.adagreatlakes.org>
- Contact them to obtain a free copy of 2010 ADA Standards (mailing costs apply)

More Information



- United States Access Board
1331 F Street, NW, Suite 1000
Washington, DC 20004-1111
 - Phone (voice): (202) 272-0080 toll free: (800) 872-2253
Phone (TTY): (202) 272-0082 toll free: (800) 993-2822
 - E-mail: info@access-board.gov
 - E-mail: ta@access-board.gov
 - Website: <http://www.access-board.gov/>
- ADA National Network & US Access Board
 - Webinar and Audio Conference Series
 - Phone: (877) 232-1990 (v/TTY)
- E-mail: adaconferences@adagreatlakes.org
 - Website: <http://www.accessibilityonline.org>



Felicia Burton, Accessibility Specialist

Capital Development Board

401 S. Spring Street

3rd Floor, William G. Stratton Building

Springfield, Illinois 62706

217-782-8530 (v)

217-524-4208 (fax)

felicia.burton@illinois.gov

Office of the Attorney General
Disability Rights Bureau
James R. Thompson Center
100 W. Randolph, 11th Floor
Chicago, Illinois 60601

(312) 814-5684 (v) or (800) 964-3013 (tty)

disabilityrights@atg.state.il.us
www.illinoisattorneygeneral.gov

Covers Illinois north of I-80



Vickie Simpson, Policy Advisor
Office of the Illinois Attorney General
Disability Rights Bureau
500 S. Second Street
Springfield, Illinois 62706
(217) 785-5726 or (217) 524-2660
(877) 844-5461 (tty)



vsimpson@atg.state.il.us

<http://www.illinoisattorneygeneral.gov>

Covers Illinois South of I-80

